

SCHEME OF STUDIES
DIPLOMA IN ELECTRICAL & ELECTRONICS ENGINEERING
(C-20)

CURRICULUM STRUCTURE

V Semester Scheme of Studies - Diploma in Electrical & Electronics Engineering [C-20]

Pathway	Course Category / Teaching Department	Course Code	Pathway Title	Hours per Semester			Total contact hrs	Credits	CIE Marks		SEE-1 Marks (Theory)		SEE-2 Mark (Practical)		Total Marks	Min Marks for Passing CIE (including CIE marks)	Assigned	Grade Point	SGPA and CGPA
				L	T	P			Max	Min	Max	Min	Max	Min					
Programme Specialization Pathway																			
1	EE Specialization pathways in emerging areas Student may select any one of the specializations	20EE51I	Industrial Automation	104	52	312	468	24	240	96	60	24	100	40	400	160			
		20EE52I	Power Engineering	104	52	312	468	24	240	96	60	24	100	40	400	160			
		20EE53I	Renewable Energy	104	52	312	468	24	240	96	60	24	100	40	400	160			
		20EE54I	Electrical Utility Engineering	104	52	312	468	24	240	96	60	24	100	40	400	160			
Science and Research Pathway				L	T	P	Total	Credits	CIE Marks		SEE Marks								
									Max	Min	Max	Min							
2	BS/SC/EE Specialization pathway in Science and Research (Student need to take all four papers in this pathway)	20SC51T	Paper 1-Applied Mathematics	52	26	0	78	6	50	20	50	20	100	40					
		20SC52T	Paper 2 – Applied Science	52	0	52	104	6	50	20	50	20	100	40					
		20RM53T	Paper 3 – Research Methodology	52	0	52	104	6	50	20	50	20	100	40					
		20TW54P	Paper 4 – Technical Writing	39	13	52	104	6	60	24	40	16	100	40					
			Total	195	39	156	390	24	210	84	190	76	400	160					
Entrepreneurship Pathway																			
3	ES/EE	20ET51I	Entrepreneurship and Start up	104	52	312	468	24	240	96	160	64	400	160					

L:- Lecture T:- Tutorial P:- Practical BS- Basic Science:: ES-Engineering Science:: SC: Science , I: Integrated

Note: In 5th Semester student need to select any one of the pathways consisting of 24 credits

Students can continue their higher education irrespective of the Pathway selected

CURRICULUM STRUCTURE

VI Semester Scheme of Studies - Diploma in Electrical & Electronics Engineering [C-20]

Pathway	Course Category / Teaching Department	Course Code	Pathway	Course		Total contact	Credits	CIE Marks		SEE Marks		Total Marks	Min Marks for Passing	Assigned Grade	Grade	SGPA and CGPA
								Max	Min	Max	Min					
Internship	ES/EE	20EE61S	Specialisation pathway	Internship/ project	40 Hours / week Total 16 Weeks	640	16	240	96	160	64	400	160			
		20EE61R	Science and Research Pathway	Research project	40 Hours / week Total 16 Weeks	640	16	240	96	160	64	400	160			
		20EE61E	Entrepreneurship and Start up pathway	Minimum Viable Product - MVP/ Incubation/ Startup proposal	40 Hours / week Total 16 Weeks	640	16	240	96	160	64	400	160			

Note : Student shall undergo Internship/Project/research project/MVP/Incubation/Startup proposal in the same area as opted

in 5th semester pathway



Government of Karnataka
DEPARTMENT OF COLLEGIATE AND TECHNICAL EDUCATION

Program	Electrical & Electronics Engineering	Semester	5
Course Code	20EE51I	Type of Course L:T:P	104 : 52 : 312
Course Name	Industrial Automation	Credits	24
CIE Marks	240	SEE Marks	160

Introduction:

Automation in the industrial workplace provides the advantages of improving productivity and quality while reducing errors and waste, increasing safety, and adding flexibility to the manufacturing process. In the end, industrial automation yields increased safety, reliability, and profitability. This specialisation course is taught in Boot camp mode. Boot camp are 12 weeks, intense learning sessions designed to prepare the students for the practical world – ready for either industry or becoming an entrepreneur. Student will be assisted through the course, with development-based assessments to enable progressive learning. Industrial automation course introduces Programmable Logic Controllers (PLC), Field level Instrumentation and SCADA/HMI Systems used for Industrial Automation. The students will get appropriate knowledge and exposure to configuration of Industrial Controllers and development of application programs. Also covers Interfacing with SCADA/HMI systems used for remote monitoring & control of industrial process units and machines.

Leading to the successful completion of this boot camp, students shall be equipped to either do an internship in an organisation working on Automation and Robotics or do a capstone project in the related field. After the completion of Diploma, student shall be ready to take up roles like a Programmer, Supervisor and can rise up to the level of Manager, also can become Entrepreneur in the related field and more.

Pre-requisite

Before the start of this specialisation course, student shall have prerequisite knowledge gained in the first two years on the following subjects:

1st year – Engineering Mathematics, computer Aided Engineering Graphics, Fundamentals of Electrical and Electronics Engineering and Basics of Electrical power system, Communication Skills, Statistics & Analysis, Basic IT Skills, Project Management skills and Residential wiring.

2nd year- Transformers and Alternators, Transmission and Distribution, Switchgear and Protection, Analog and Digital electronics, Electrical motors, Power electronics, Fundamentals of Automation Technology and Computer Aided Electrical Drawing.

In the third year of study, student shall be applying previous years learning along with specialised field of study into projects and real-world applications.

Course Cohort Owner

A Course Cohort Owner is a faculty from the core discipline, who is fully responsible for one specialised field of study and the cohort of students who have chosen to study that specialised field of study.

Guidelines for Cohort Owner

1. Each Specialized field of study is restricted to a Cohort of 20 students which could include students from other relevant programs.
2. One faculty from the Core Discipline shall be the Cohort Owner, who for teaching and learning in allied disciplines can work with faculty from other disciplines or industry experts.
3. The course shall be delivered in boot camp mode spanning over 12 weeks of study, weekly developmental assessments and culminating in a mini capstone.
4. The industry session shall be addressed by industry subject experts (in contact mode/online / recorded video mode) in the discipline only.
5. The cohort owner shall be responsible to identify experts from the relevant field and organize industry session as per schedule.
6. Cohort owner shall plan and accompany the cohort for any industrial visits.
7. Cohort owner shall maintain and document industrial assignments, weekly assessments, practices and mini project.
8. The cohort owner shall coordinate with faculties across programs needed for their course to ensure seamless delivery as per time table
9. The cohort owner along with classroom sessions can augment or use supplementary teaching and learning opportunities including good quality online courses available on platforms like Karnataka LMS, Infosys Springboard, NPTEL, Unacademy, SWAYAM, etc.

Course outcome:

On successful completion of the course, the students will be able to:

C01	Develop and test the PLC program for a given industrial application using simulation software.
C02	Install, troubleshoot and maintain the PLC.
C03	Interface VFD/servo motor with HMI and PLC to control various motor parameters.
C04	Automate the given process and troubleshoot the system for its defects.
C05	Interface SCADA /HMI with PLC and Control PLC from SCADA.

Detailed Course Plan

Week	C O	P O	Days	1 st session (9 am to 1 pm)	L	T	P	2 ND session (1.30 pm to 4.30 pm)	L	T	P
1	1	3	1	Introduction to industrial automation: Video on automation <ul style="list-style-type: none"> • Why automation is required? • Examples to understand industrial automation • Motivation for Industrial Automation • Levels of Industrial Automation Process • Types of automation. • What can be automated and what cannot be automated? 	3		1	<ul style="list-style-type: none"> • Introduction to process automation • Familiarizing with process control system Video demonstration: <ul style="list-style-type: none"> • Demonstrate the various automation processes. 	1		2
	1	3	2	<ul style="list-style-type: none"> • Familiarizing and learning open loop and close loop systems with examples. • Demonstrate a closed-loop feedback system with a different applications • Demonstrate the different components used in process control. • Demonstrate how the process control system works. 	2		2	Video Demonstration on <ul style="list-style-type: none"> • Automation of the beverage industry • Automation of motor stator production. • Automation of Transformer core • The Role of PLCs in manufacturing • PLC application stories 			3
	1	2,3,4	3	Advance PLC instructions Bit Logic Instructions: Standard Contacts, Immediate Contacts, NOT Instruction, Positive and Negative Transition Instructions, Output, Output Immediate, Set and Reset, Set Immediate and Reset Immediate <ul style="list-style-type: none"> • Normally Open 	2		2	Develop a LAD (Ladder diagram) to control the stamp system. Identify and select sensors ,switches and actuators required to implement the sytem. An automatic stamp system shown in Figure 2 works as follows: When start switch is turned on, system gets ready to run. When the operator puts a box at the beginning of the conveyor (on LS1) the motor runs and conveyor moves. Upon			3

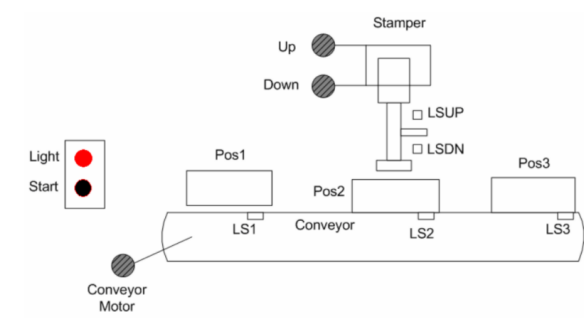
			<ul style="list-style-type: none"> • Normally Close • NOT logic • Coil • Set Coil • Reset Coil • Negative Edge • Positive Edge <p>Demonstration of instructions Explain the five steps to PLC Program development</p> <ul style="list-style-type: none"> • Define the task. • Define the inputs and outputs. • Develop a logical sequence of operation. • Develop the PLC program. • Test the program. 			<p>reaching the midpoint of the conveyor (on LS2) the conveyor motor stops. Then the stamp comes down and puts the stamp on the box. When this process is finished, the stamp goes up and conveyor moves again to the other end of the conveyor. After box reaches to end of the conveyor (on LS3), the motor stops. The system waits for the box to get and the box to be placed at the beginning of the conveyor. If start switch is turned off, the system cannot run even if there is a box on conveyor. The light on the start box indicates that the system is active whereas UP and Down lights indicate that the stamp is UP and DOWN position respectively.</p> 		
1	2,3,4	4	<ul style="list-style-type: none"> • To study the operation of different types of timers. • Timer Instructions: On-Delay Timer, Retentive On-Delay Timer, Off-Delay Timer • Counters: Count Up Counter, Count Down Counter, Count Up/Down Counter <p>Develop and Test a LAD (Ladder diagram)/ Functional Block Diagram(FBD) using simulation software, for the process mixer.</p>	2	2	<p>Develop and Test a LAD (Ladder diagram)/ Functional Block Diagram (FBD) for the given system using simulation software. Identify and select sensors ,switches and actuators required to implement the sytem.</p> <p>The system to be controlled by PLC consists of two belts. If the Start button is pressed, Conveyor Belt-1 will begin to run. After 5 seconds Conveyor Belt-2 will be active. After the whole system runs</p>		3

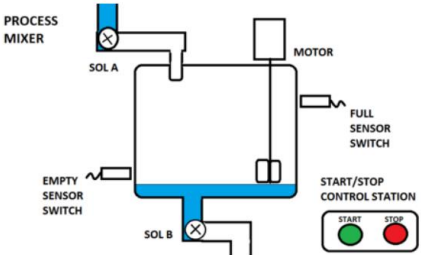
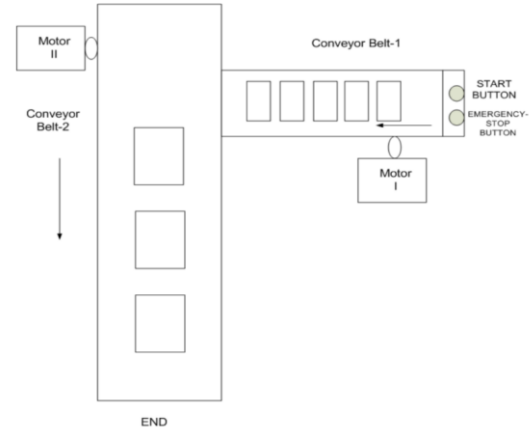
			<p>Identify and select sensors, switches and actuators required to implement the sytem.</p> <p>A normally open start and normally closed stop pushbuttons are used to start and stop the process. When the start button is pressed, solenoid A energizes to start filling the tank. As the tank fills, the empty level sensor switch closes. When the tank is full, the full-level sensor switch closes. Solenoid A is de-energized. The mixer motor starts and runs for 3 minutes to mix the liquid. When the agitate motor stops, solenoid B is energized to empty the tank. When the tank is completely empty, the empty sensor switch opens to de-energize solenoid B. The start button is pressed to repeat the sequence.</p> 				<p>For 15 seconds, Conveyor Belt-1 will stop. Then Conveyor Belt-2 continues to move for 5 seconds And then it will stop, too. Also the system can be reset by the emergency-stop button at any time.</p> 				
			5	Developmental Assessment	-	-	-	Assessment Review and corrective action			3
			6	Industry Class+ Assignment PLC programming	2		3				
2	1	2,3,4	1	Peer discussion on Industrial assignment		4		Shift register Instructions Practice of Instructions	1		2

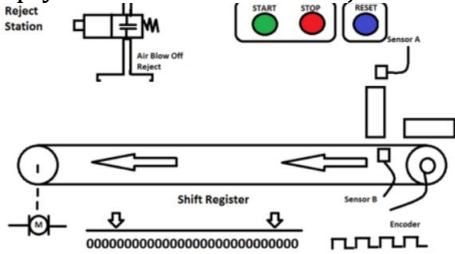
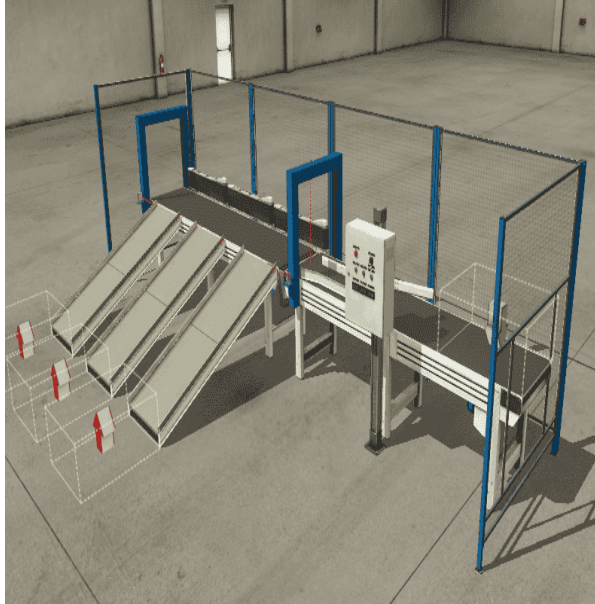
			<p>Develop and Test a LAD/FBD for the given system using simulation software. Identify and select sensors, switches and actuators required to implement the sytem.</p> <p>Empty bottle detection and rejection.</p>  <p>A start pushbutton (NO) is used to start the conveyor and a stop pushbutton (NC) is used to stop. Sensor B detects a product on the conveyor belt and sensor A will detect if it is too large and needs to be rejected. The product is tracked along the conveyor belt and when under the reject station the Reject Blow Off will expel the bad product. The product is randomly placed on the conveyor belt, so an incremental encoder is used to track the conveyor movement. The reset pushbutton (NO) will signal that all of the product on the conveyor has been removed between the sensors and reject blow-off.</p>	1	3	<p>Develop and test a LAD /FBD using simulation software to sort three different types of jobs. identify sensors, switches and actuators required to implement the sytem.</p> 			3
1	2,3	3	<p>Program Control Instructions: Jump Instructions, Subroutine Instructions, Calling a Subroutine With Parameters. Comparison Instructions in PLC Programming. Equal (EQU) Instruction</p>	2	2	<p>Automatic Bottle Filling System using PLC. Develop and Test a LAD for this system using simulation software. Identify and select sensors ,switches and actuators required to implement the sytem.</p>			3

				Not Equal (NEQ) Instruction Less than (LES) Instruction Less Than or Equal (LEQ) Instruction. Greater Than (GRT) Instruction. Greater than or Equal (GEQ) Instruction. Limit Test (LIM) Instruction.						
1	2,3,4	4	Math Instructions: Multiply Integer to Double Integer and Divide Integer with Remainder, Multiply Integer to Double Integer and Divide Integer with Remainder, Increment and Decrement Instructions. MOV and Masked MOVE instructions Practice of Instructions	2		2	Develop LAD/ Functional Block Diagram (FBD) for the parking lot controller by using math instructions. Do not use counter instructions? Identify and select sensors ,switches and actuators required to implement the sytem. The parking lot which has a capacity of 100 cars is to be controlled by a PLC system. The sensor S1 and S2 are used to count the car at the entrance and exit. If the number of the cars reaches to 100, red light is lit and the gate arm is closed. The arm stays closed until one or more parking space is available in the lot. The gate arm is controlled by activating/deactivating the gate solenoid (GS).			3

		5	Developmental Assessment	-	-	Assessment Review and corrective action				
		6	Industry Class + Assignment (PLC programming)	2	3					
3	2	4	1	Peer discussion on Industrial assignment.	4	Making and wiring of PLC based control panel The Evolution of PLCs in Industrial Automation. <ul style="list-style-type: none"> • Identify different types of PLCs • Identify different brands of PLCs • Comparison of different brands of PLCs • Selection of PLC for given industrial application 	1		2	

	2	4	2	Elements of logic panel: DIN rail for equipment, mounting, Cable channel. Terminal for wire connection, VFD, PLC, Power supply, SMPS. Relay, Contactor, Fan, Connectors, Input outputs module, Power sockets, Transformer, HMI, Selector switch, Push button, Indicating lamp, etc.	1		3	<ul style="list-style-type: none"> Safety measures for PLC installations in control panels. Demonstrate all tools that are required for making the PLC control panel. 			3
	2	4	3	To cut DIN rail as per our requirements and fixed in the control panel	1		3	To Mount different devices on DIN rail			3
	2	4	4	<ul style="list-style-type: none"> To connect all equipment by different types of cables. Check all connections before powering on the control panel multimeter. 	1		3	Demonstration of SMPS and their connections			3
			5	CIE 1- Written and practice test	-	-	-	Assessment Review and corrective action			3
			6	Industry Class + Assignment (PLC control panel)	2		3				
4	2	4	1	Peer discussion on Industrial assignment		4		Installation, Troubleshooting and maintenance of PLC <ul style="list-style-type: none"> Safety precautions when installing PLC systems. Power requirements and safety circuitry Power requirements: Common AC Source. Isolation Transformers. Safety circuitry: Emergency Stops, Master control relay (MCR) and safety control relay (SCR), Emergency Power Disconnect. 	1		2

	2	4	2	<ul style="list-style-type: none"> I/o installation, wiring, and precautions I/o module installation, Wiring considerations: wire size, wire and terminal labelling. Wire bundling. Wire bundling Wiring procedures Special i/o connection precaution: 	1		3	PLC START-UP AND CHECKING PROCEDURES: Static input wiring check, static output wiring check, dynamic system checkout			3
	2	4	3	<ul style="list-style-type: none"> PLC system maintenance: preventive maintenance: guidelines for preventive measures: spare parts, replacement of I/O modules. Common Causes of Programmable Logic Controller Failure Classification of Faults in a PLC System. Trouble shooting of Hardware faults 	1		3	Troubleshooting the PLC system: <ul style="list-style-type: none"> Troubleshooting ground loops Diagnostic indicators Troubleshooting plc inputs Troubleshooting plc outputs Troubleshooting the CPU Troubleshooting Specific Components of the PLC System Power Supply Trouble shooting Troubleshooting PLC Program Errors Troubleshooting the Working Environment of a PLC 			3
	2	4	4	Types of software faults Access various troubleshooting resources provided in the software to diagnose the faults with the PLC system.	1		3	Access various troubleshooting resources provided in the software to diagnose the faults with the PLC system.			3
			5	Developmental Assessment			-	Assessment Review and corrective action			3
			6	Industry Class + Assignment (Trouble shooting of PLC)			3				
Week	C O	P O	Days	1st session (9am to 1 pm)	L	T	P	2ND session (1.30pm to 4.30pm)	L	T	P
5	3	1	1	Peer discussion on Industrial assignment		4		VFD <ul style="list-style-type: none"> Familiarizing AC motor speed is controlled using the voltage or frequency. 	2		1

							<ul style="list-style-type: none"> Familiarizing constant flux density. And AC induction motors. 			
	3	4	2	<ul style="list-style-type: none"> Building blocks of VFDs, specifications, types and working principles. Torque/current Vs frequency characteristics. Sizing of VFD VFD with motor control panel, modules of VFD. Industrial and domestic applications of VFDs. Selection of VFD for a given application. 	2	2	Wire and test VFD with motor control panel			3
	3	4	3	<ul style="list-style-type: none"> Test the communication port, cable and module of VFD. Connect and Commission the given VFD Configure and run the motor with factory settings. Troubleshooting of VFD. 	1	3	Mounting of Variable Frequency Drive To operate Variable Frequency Drive. Set and control the speed of motor by VFD.			3
	3	4	4	Diagnose the simulated faults and explore the remedial measures of AC drives. <ul style="list-style-type: none"> Connection of Variable Frequency Drive with PLC and motor 	1	3	Motor Speed Control using VFD and PLC			3
			5	CIE 2- Written and practice test	-	-	Assessment Review and corrective action			3
			6	Industry Class + Assignment (Industrial application of VFD)	2	3				
6	3	1	1	Peer discussion on Industrial assignment		4	Servo motors: <ul style="list-style-type: none"> Fundamentals of Servo motors and motion control applications. Servo motors, specifications 	1		2

								<ul style="list-style-type: none"> servo drives and AC Drives, principle of operation and its applications in motion control, precision measurements etc. Demonstration of servo motor applications. 			
	3	4	2	Wire and test Servo drive. Connect and Commission the given servo Drive. <ul style="list-style-type: none"> Servo drive for electric mobility application Unguided vehicle(UGV) Servo drive for robotic applications 	1		3	Configure and run the motor with factory settings.			3
	3	4	3	<ul style="list-style-type: none"> Diagnose the simulated faults and explore the remedial measures of servo drives. 	1		3	<ul style="list-style-type: none"> Various communication standards and protocols used in Drives. Communication cables and adapters. Various Fault diagnosis in the communication modules. 	1		2
	3	4	4	<ul style="list-style-type: none"> Connect the Drive with a computer, configure and establish communication. Configure the drive for various applications using the software. Troubleshooting of Servo drive. 	1		3	<ul style="list-style-type: none"> Monitor various motor parameters using the given drive software. 			3
			5	Developmental Assessment	-	-		Assessment Review and corrective action			3
			6	Industry Class + Assignment (Industrial application of servomotor)	2		3				
Week	C O	P O	Days	1st session (9am to 1 pm)	L	T	P	2ND session (1.30pm to 4.30pm)	L	T	P
7	5	4	1	Peer discussion on Industrial assignment		4		PLC with colour Touch screen Human Machine Interface (HMI):	1		2

							• Colour Touch Screen HMI panels and specifications, various industry interfaces on HMI panels, features of HMI panels				
	5	4	2	Working with HMI software Tool • Configure PLC with HMI • Animation with graphical objects • Troubleshooting of communication problems with drive/PLC • Set up and configure HMI with PLC and Perform supervisory control to turn on/off output field devices -1	2		2	Set up and configure HMI with PLC and Perform supervisory control to turn on/off output field devices -2			3
	5	4	3	• Animate objects on a HMI screen to monitor motor status. • Trend the data of a process parameter using a trend tool.	1		3	• Create user groups and monitor screens with proper authentication. • Use security features to do tag logging and command execution.			3
	5	4	4	• Control the servo motor from PLC on a network for various operations such as acceleration, and deceleration. • Configure a servo Drive from the given PLC and Control the motor speed for fixed steps for indexing operations and integrate the given PLC, SCADA/HMI and VFD systems to automate the given process. -1	1		3	Configure a servo Drive from the given PLC and Control the motor speed for fixed steps for indexing operations and integrate the given PLC, SCADA/HMI and VFD systems to automate the given process. -2			3
			5	CIE 3 Written and practice test				Assessment Review and corrective action			3
			6	Industry Class + Assignment (Integrate HMI with PLC)	2		3				
8	4	1	1	Peer discussion on Industrial assignment.		4		Introduction to basic pneumatic components	2		1

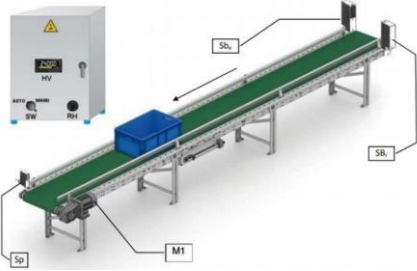
			<p>Wire, program and automate a working model Applications. :</p> <p>Wiring and identifying the sensors and valves in the batch process reactor plant and programming it for mixing of the two ingredients-1 OR Design, construct, install, configure, test and demonstrate the operation of an industrial conveyor of empty boxes -1</p>  <p>Description of operation:</p> <ul style="list-style-type: none"> • If there is no box to convey, the device is off; • If a box is detected by Sb, the conveyor is turned on and the speed of the treadmill must be reached in 5 seconds; • The box is conveyed at a speed of 25 cm/s in auto mode; • Speed can be regulated by user in manual mode with a potentiometer and displayed on the front door of the control box; 	1		3	<p>Wire, program and automate a working model Applications. :</p> <p>Wiring and identifying the sensors and valves in the batch process reactor plant and programming it for mixing of the two ingredients-2 OR Design, construct, install, configure, test and demonstrate the operation of an industrial conveyor of empty boxes -2</p>			3
--	--	--	---	---	--	---	--	--	--	---

			<ul style="list-style-type: none"> • The conveyor is turned off if the box finished its course on the treadmill detected by sensor Sp AND no new box has been inserted for 10 seconds; <p>Description of contents</p> <ul style="list-style-type: none"> • M1 is a three-phase asynchronous motor 230 V / 400 V, 0, 18 kW; • Sp is a photo-electric sensor, diffuse system, 24 VDC, negative; • Sb is a photo-electric sensor, thru-beam, (Sbe = Emitter; Sbr = Receiver) 24 VDC, negative • SW is a selector switches with 2 NO contacts and standard or long handle. • RH is a potentiometer to regulate speed in manual mode; • Speed driver is a SCHNEIDER Altivar ATV12 H018 M3; • HV is a digital display of the speed. 							
4	4	3	Wire, program and automate a working model Applications: Automatic sorting station.-1	1		3	Wire, program and automate a working model Applications : Automatic sorting station.-2			3
4	4	4	Wire, program and automate a working model Applications. : PLC based Automatic Packaging System-1.	1		3	Wire, program and automate a working model Applications. : PLC based Automatic Packaging System-2.			3
		5	Developmental Assessment				Assessment Review and corrective action			3
		6	Industry Class + Assignment (Automating industrial process)	2		3				

9	4	1	1	Weekly Assignment review	-	4	-	Introduction to IOT <ul style="list-style-type: none"> Main components used in IoT Ways of building IoT: Characteristics of IoT: Modern Applications: Demonstrate application of IoT	2		1
	4	1	2	<ul style="list-style-type: none"> Communication devices in IoT Needs for setting up IoT environment for basic applications Choosing a platform for IoT development AWS IoT: (Amazon Web Services) Microsoft Azure IoT: Choosing IoT hardware processor: Arduino -Set up – procedure, Advantages: Raspberry Pi - Set up – procedure, Advantages: Need to use Bluetooth beacons 	2		2	<ul style="list-style-type: none"> Introduction to NODE MCU ESP8266 (WIFI module) Automate a system to control appliances from anywhere through the internet. 	1		3
	4	1,4	3	IoT-based Smart Energy Meter using NodeMCU ESP8266	1		3	<ul style="list-style-type: none"> What is Raspberry pi and why is it important for IoT IoT-based Smart Energy Meter using Rasberry PI 			3
	4	4	4	<ul style="list-style-type: none"> IoT-Based Home Appliances Control with Adafruit IO and Raspberry Pi 	1		3	<ul style="list-style-type: none"> Applying IoT technologies in the Electric Power Industry IIoT in Industrial Automation The essentials of an Industrial IoT solution 	1		2

			<ul style="list-style-type: none"> IoT-based Home Automation using Blynk App and Raspberry PI 				<ul style="list-style-type: none"> Practical Industrial IoT examples for daily use 			
4		5	CIE 4 Written and practice test	-	-	-	Assessment Review and corrective action			3
		6	Industry Class + Assignment (Automating industrial process)	2		3				

Week	C O	P O	Days	1 st session (9am to 1 pm)	L	T	P	2 ND session (1.30pm to 4.30pm)	L	T	P
10	5	4	1	Peer discussion on Industrial assignment		4		Interconnect PLC systems with different industry standard communication protocols for data transfer. <ul style="list-style-type: none"> Need for Industrial networking brief history Different types of networking architecture Topology 	3		
	5	1	2	<ul style="list-style-type: none"> OSI model of networking Networking hardware Network standards <ul style="list-style-type: none"> Modbus, CAN bus, ControlNet, Ethernet, Profibus FIP I/O, etc 	4		Proprietary Network standards and protocols: Master Slave Configurations.	3			
	5	4	3	<ul style="list-style-type: none"> Communication Driver software and Communication hardware modules Network / communication driver software install and settings for PLC and SCADA. 			4	<ul style="list-style-type: none"> Remote Terminal Units. . Scheme of Remote I/O 	3		

	5	4	4	Demonstrate Industrial Automation Communication Protocols - RS232-422-485 standards			4	Demonstrate HART and MODBUS, PROFIBUS, DH-485 and Foundation fieldbus etc.			3
			5	Developmental Assessment				Assessment Review and corrective action			3
			6	Industry Class + Assignment (Industry standard communication standards)	2		3				
Week	C O	P O	Days	1 st session (9am to 1 pm)	L	T	P	2 ND session (1.30pm to 4.30pm)	L	T	P
11	5	1	1	Peer discussion on Industrial assignment		4		Supervisory data control and acquisition system (SCADA) Introduction to SCADA: <ul style="list-style-type: none"> • What is SCADA? • SCADA SYSTEMS • Evolution of SCADA • Objective of SCADA. • Benefits of SCADA • Functions of SCADA: • SCADA APPLICATIONS • Usage of SCADA • Real-Time Monitoring and Control using SCADA 	3		
				5	4	2	SCADA HARDWARE: <ul style="list-style-type: none"> • SCADA Hardware Functions, • Remote Terminal Units (RTU): RTU Hardware: A typical single-board RTU. • Hardware functionality in an RTU, RTU Software functions • Basic operation: RTU Standards. • Difference between PLC and RTU • Features of SCADA 	2	2	SOFTWARE AND PROTOCOLS. <ul style="list-style-type: none"> • DNP3 Protocol: Important Features of DNP3. • IEC60870 PROTOCOL The two widely used protocols for SCADA Applications : <ul style="list-style-type: none"> • HDLC (High-Level Data Link Control) • MODBUS The widely-used open software for SCADA systems : <ul style="list-style-type: none"> • Citect and Wonderware. 	

				<ul style="list-style-type: none"> Configuration for SCADA environment and applications. SCADA Software Introduction. 							
	5	4	3	<ul style="list-style-type: none"> Simple Digital System implementation in SCADA software. Simple analog System implementation in SCADA software 	1		3	Create SCADA Animation in SCADA software			3
	5	4	4	Conveyor Animation Example in SCADA	1		3	Visibility Concept in SCADA			3
		4	5	CIE 5 Written and practice test	-	-		Assessment Review and corrective action			3
			6	Industry Class + Assignment	2		3				
Week	C O	P O	Days	1st session (9am to 1 pm)	L	T	P	2ND session (1.30pm to 4.30pm)	L	T	P
12	5	4	1	Peer discussion on Industrial assignment		4		<ul style="list-style-type: none"> Interfacing of SCADA with PLC Master Terminal Unit (MTU) Remote Terminal Unit (RTU) 	1		2
	5	4	2	Control PLC from SCADA <ul style="list-style-type: none"> PLC ladder logic to control variable frequency drive (VFD) for motor speed control with speed selection from Field Local Panel or SCADA graphics.-1 	1		3	Control PLC from SCADA PLC ladder logic to control variable frequency drive (VFD) for motor speed control with speed selection from Field Local Panel or SCADA graphics-2			3
	5	4	3	Digital Alarms Interfacing with PLC	1		3	Analog Alarms Virtual Simulation			3
	5	4	4	Analog Alarms Interfacing with PLC Basic Report Generation-1	1		3	Analog Alarms Interfacing with PLC Basic Report Generation-2			3
			5	Developmental Assessment				Assessment Review and corrective action			3
			6	Industry Class + Assignment (Application of SCADA in automation)	2		3				

Week	C O	P O	Days	1 st session (9am to 1 pm)	L	T	P	2 ND session (1.30pm to 4.30pm)	L	T	P
13	1,2, 3,4, 5	2,3, 4		Internship a) Secondary research on various industries and their operations to identify at least 3 companies along with the areas of work interest and develop an internship plan that clearly highlights expectations from the industry during the internship. b) Design and develop a cover letter for an internship request to all 3 identified companies and the resume to be submitted to potential companies. c) Prepare for an internship interview to highlight your interests, areas of study, career aspirations and personnel competence – including the areas of learning you expect to learn during the internship		4		Project a) Identification of the problem statement (from at least 3 known problems) the students would like to work as part of the project – either as provided by faculty or as identified by the student. Document the impact the project will have from a technical, social and business perspective. b) Design and develop the project solution or methodology to be used to solve at least one of the problems identified. Prepare a project plan that will include a schedule, WBS, Budget and known risks along with strategies to mitigate them to ensure the project achieves the desired outcome.			3

Reference:

Sl. No.	Description
1	Programmable Logic Controllers: John W.Webb, Ronald A.Reis, PHI
2	Introduction to PLC by Gary Dunning, Cengage Learning.
3	Mechatronics: W.Bolton
4	Control of Machines- S.K. Bhattacharya & Brijinder Singh, New Age International Publishers
5	https://foodsafetytech.com/column/automation-benefits-food-beverage-industry/
6	PLC Handbook https://cdn.automationdirect.com/static/eBooks/PLC%20Handbook.pdf
7	https://www.electrical4u.com/industrial-automation
8	https://support.industry.siemens.com/cs/document/109782616/logo!-soft-comfort-v8-demo?dti=0&lc=en-WW
9	https://new.siemens.com/in/en/products/automation/systems/industrial/plc/logo/logo-demosoftware.html

10	Programming a daily timer on LOGO PLC: https://www.youtube.com/watch?v=R12VIBUVr-0
11	Siemens Logo 8 Pump Start & Stop Control With Set Pressure: https://www.youtube.com/watch?v=gf0ZwrVvn_4
12	https://nptel.ac.in/content/storage2/courses/112106175/downloads/Module%204/SELF%20EVALAUTION/SE-Lecture%2041.pdf
13	https://accautomation.ca/wiring-push-buttons-and-selector-switch-to-click-plc/
14	https://realpars.com/discrete-sensors-part-1/
15	https://www.automationdirect.com/adc/overview/catalog/sensors_-z_ encoders
16	https://www.rtautomation.com/technologies/control-iec-61131-3/
17	https://davidrojasplc.files.wordpress.com/2009/01/libro-en-espanol.pdf
18	https://instrumentationblog.com/bit-logic-plc-programming-examples/
19	https://accautomation.ca/plc-programming-example-shift-register-conveyor-reject/
20	https://instrumentationtools.com/plc-program-for-counting-moving-objects-on-conveyor/
21	https://accautomation.ca/plc-programming-example-process-mixer/
22	https://automationforum.co/plc-program-batch-process/
23	https://instrumentationtools.com/plc-program-for-mixing-tank/#:~:text=When%20the%20normally%20closed%20%E2%82%82oat.mix%20the%20two%20liquids%20together.
24	https://accautomation.ca/plc-programming-example-sorting-station-shift-register/
25	https://instrumentationtools.com/car-parking-system-plc-programming/
26	https://learn.automationcommunity.com/car-parking-plc-program/
27	https://www.sanfoundry.com/plc-program-remove-empty-detected-bottle-conveyor/
28	Automatic bottle filling and capping: https://www.youtube.com/watch?v=JdXzMI1PXcs
29	https://instrumentationtools.com/plc-program-to-control-level-of-two-tanks/
30	https://www.reliance-scada.com/en/download/reliance4/reliance4-example-projects
31	https://electrical-engineering-portal.com/plc-troubleshooting
32	https://www.plctutorialpoint.com/2016/05/plc-fault-finding-troubleshooting.html
33	https://instrumentationtools.com/hardware-troubleshooting-steps-for-plc-automation-systems/
34	https://instrumentationtools.com/how-modbus-communication-works/
35	https://instrumentationtools.com/plc-program-to-control-motor-speed-using-vfd-drive/
36	https://instrumentationtools.com/how-to-control-vfd-with-plc/
37	https://realpars.com/connect-vfd-to-plc/
38	https://forumautomation.com/t/plc-selection-criterias/4383
39	https://www.plctechnician.com/news-blog/evolution-plcs
40	SCADA applications in manufacturing SCADA process control systems: https://www.youtube.com/watch?v=f0bw2DE-cos&list=RDCMUCFnjTv9IIHlOPk6u_i8CjWQ&index=6
41	SCADA colour mixing recipe management: https://www.youtube.com/watch?v=S6giv9rIRNA&list=RDCMUCFnjTv9IIHlOPk6u_i8CjWQ&index=13
42	Introduction to SCADA System Supervisory Control and Data Acquisition System: https://www.youtube.com/watch?v=86uY3TQq2Yk https://nptel.ac.in/courses/108106022

43	https://bin95.com/industrial-training-videos/ab-plc-dh485-rs232-usb.htm
44	https://www.geeksforgeeks.org/introduction-to-internet-of-things-iot-set-1/
45	<p>Introduction to IOT</p> <p>a.https://infyspringboard.onwingspan.com/web/en/viewer/video/lex_auth_01281271072738508814673_shared?collectionId=lex_auth_0130944265535569922151_shared&collectionType=Course</p> <p>b.https://www.geeksforgeeks.org/internet-things-iot-2/</p>
46	<p>Introduction to NODE MCU ESP8266 (WIFI module)</p> <p>https://www.nodemcu.com/index_en.html</p> <p>Automation system to control appliances from anywhere through the internet.</p> <p>https://easyelectronicsproject.com/esp32-projects/esp8266-mqtt-home-automation-system/</p>
47	<p>IoT based Smart Energy Meter using NodeMCU ESP8266</p> <p>https://iotdesignpro.com/projects/iot-based-smart-energy-meter-using-nodemcu-esp8266</p> <p>https://iotdesignpro.com/projects/iot-based-smart-energy-meter</p>
48	<p>What is Raspberry pi and why is it important for IoT</p> <p>https://analyticsindiamag.com/raspberry-pie-important-iot/</p> <p>IoT based Smart Energy Meter using Raspberry pi</p> <p>https://circuitdigest.com/microcontroller-projects/iot-based-raspberry-pi-smart-energy-meter</p>
49	<p>IoT Based Home Appliances Control with Adafruit IO and Raspberry Pi</p> <p>https://iotdesignpro.com/iot-based-home-appliances-control-adafruit-io-and-raspberry-pi</p> <p>IoT based Home Automation using Blynk App and Raspberry Pi</p> <p>https://iotdesignpro.com/raspberry-pi-projects?page=4</p>
50	<p>Applying IoT technologies in the Electric Power Industry</p> <p>https://www2.deloitte.com/xe/en/insights/focus/internet-of-things/iot-in-electric-power-industry.html</p>
51	<p>Practical Industrial IoT examples for daily use</p> <p>https://www.ixon.cloud/knowledge-hub/7-practical-applications-of-iiot-in-industrial-automation</p>
52	https://instrumentationtools.com/problem-on-plc-hmi-vfd-and-motor-circuit/
53	<p>PLC Troubleshooting</p> <p>https://electrical-engineering-portal.com/plc-troubleshooting</p> <p>https://www.dosupply.com/tech/2022/06/01/plc-troubleshooting-flowchart-and-explanation/</p>
54	https://instrumentationtools.com/hardware-troubleshooting-steps-for-plc-automation-systems/#h-how-to-troubleshoot-the-plc-hardware-faults
55	<p>https://www.electricityforum.com/iep/electric-motors-and-drives/vfd-sizing</p> <p>https://www.focusondrives.com/how-do-you-size-a-vfd/</p>

	https://www.elitecontrols.us/how-do-you-size-a-variable-frequency-drive-vfd/ http://www.vfds.org/vfd-application-guide-379829.html
56	https://instrumentationtools.com/vfd-commissioning-and-testing-procedure-variable-frequency-drive/
57	VFD www.newark.com › agilent › TroubleshootingVFD cdn.logic-control.com › media › abb https://www.pesquality.com/blog/general-troubleshooting-of-vfd-problems https://instrumentationtools.com/how-to-control-vfd-with-plc/
58	https://www.ato.com/servo-drive-troubleshooting https://gesrepair.com/servo-motor-drive-troubleshooting-guide/
59	https://instrumentationtools.com/fieldbus-profibus-hart-protocols/

CIE and SEE Assessment Methodologies

CIE Assessment	Assessment Mode	Duration In hours	Max Marks
Week 3	CIE 1- Written and practice test	4	30
Week 5	CIE 2- Written and practice test	4	30
Week 7	CIE 3- Written and practice test	4	30
Week 9	CIE 4- Written and practice test	4	30
Week 11	CIE 5- Written and practice test	4	30
	On line Course work (Minimum 10 hours online course with certification from (SWAYAM/NPTEL/Infosys Springboard)		40
	Profile building for Internship / Submission of Synopsys for project work		20
Portfolio evaluation (Based on industrial assignments and weekly developmental assessment) *			30
TOTAL CIE MARKS (A)			240
SEE 1 - Theory exam (QP from BTE) Conducted for 100 marks 3 hrs duration reduced to 60 marks		3	60
SEE 2 - Practical		3	100
TOTAL SEE MARKS (B)			160
TOTAL MARKS (A+B)			400

* The industrial assignment shall be based on peer-to-peer assessment for a total of 10 marks (on a scale of 1 to 10) and in the event of a group assignment the marks awarded will be the same for the entire group, the developmental assessment will be for a total of 20 marks and based on MCQ/case study/demonstration and such other assignment methods

Assessment framework for CIE (1 to 5)

Note : Theory to be conducted for 1 hour and practice for 3 hours, total duration of exam - 4 hours

Programme	Electrical & Electronics Engineering	Semester	V
Course	Industrial Automation	Max Marks	30
Course Code	20EE51I	Duration	4 hours
Name of the course coordinator			

Note: Answer one full question from each section.

Qn.No	Question	CL L3/L4	CO	PO	Marks
-------	----------	-------------	----	----	-------

Section-1 (Theory) - 10 marks

1.	<p>PLC connected to a pair of pushbutton switches and light bulbs as shown in this illustration: Examine the following relay ladder logic (RLL) program determining the necessary switch statuses to energize lamp Y, and the necessary switch statuses to energize switch Z:</p>	L4	1	2	10
----	---	----	---	---	----

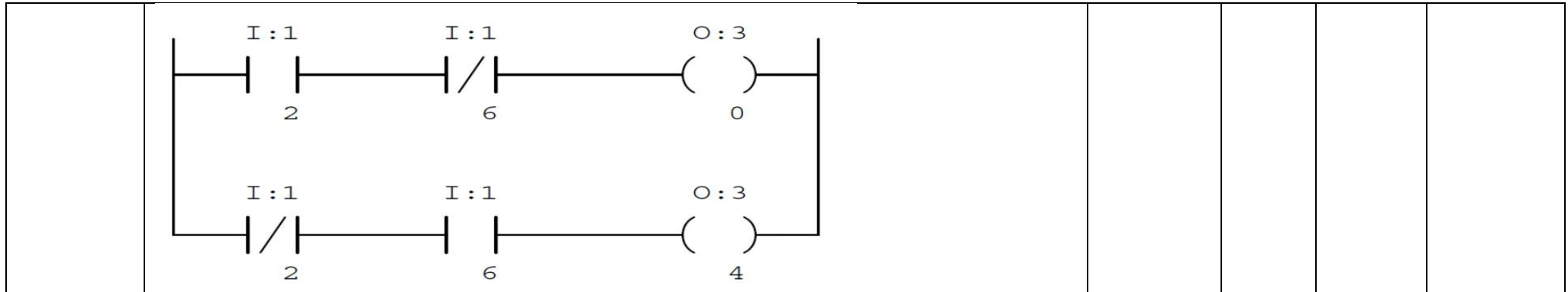

2. Suppose we have a PLC connected to three pushbutton switches as shown in this illustration:

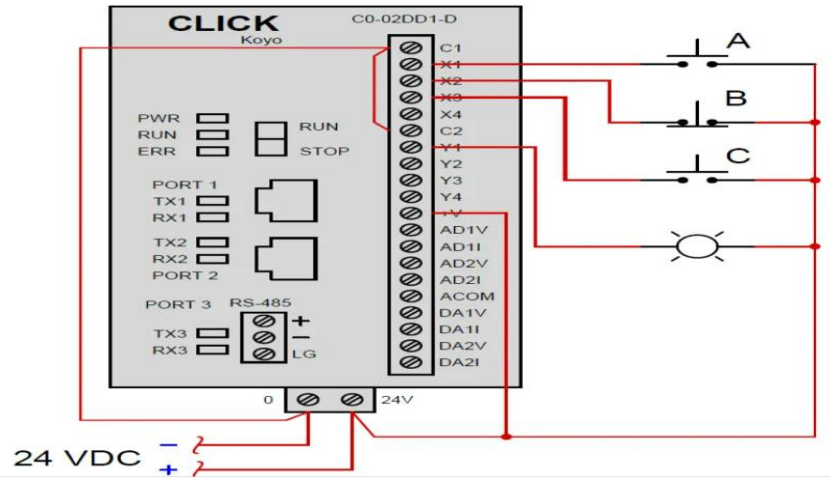

Sketch a Ladder Diagram program for this PLC to energize the lamp if the following input conditions are met:

- Switch A pressed
- Switch B pressed
- Switch C unpressed

1

2

10

Section-2 (Practical) - 20 marks

3. Write the PLC circuit for the following condition, simulate and execute.

L3

1

4

20

	<p>When PB1 is pressed feed unit advance & motor runs for 5 secs only if the job is present and clamped then return back. After delay of 3 secs cycle repeats until PB4 is pressed. Each operation can also be operated manually by individual push buttons Parameter: PB3 press everything off. Cycle should repeat if PB1 press again after completion of one cycle</p>				
--	---	--	--	--	--

Note : Theory questions shall be aligned to practical questions

Assessment framework for SEE 1 (Theory)

Programme :	Electrical & Electronics Engineering	Max Marks :	100
Semester :	V	Duration :	3 Hrs
Course :	Industrial automation		
Course Code :	20EE51I		

Instruction to the Candidate: Answer one full question from each section.

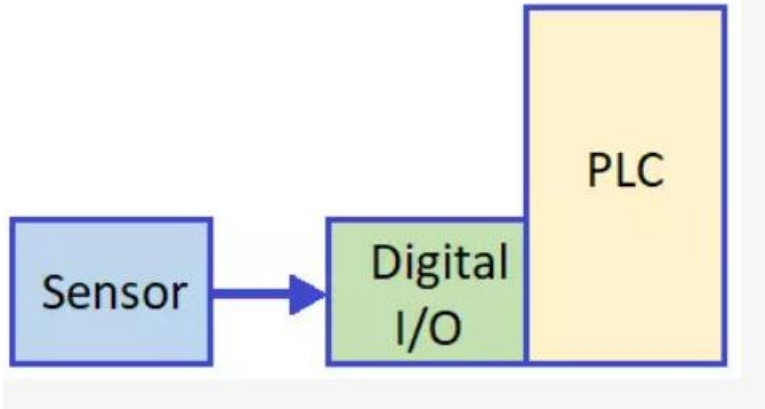
Q.No	Question	CL	CO	Marks
Section-1				
1.a)	Write the PLC circuit for the following condition When PB1 is pressed L1 gets ON after 10sec L1 off L2 ON there after 15 sec L2 OFF L3 ON, blinks with delay of 1sec for 10 times then gets OFF Parameter: PB3 press everything off. Cycle should repeat if PB1 press again after completion of one cycle.	L4	1	10
b)	 <p>Pick an appropriate sensor for the circuit shown below and justify the selection.</p>	L3		5
c)	Select sensors ,switches and actuators required to implement the sytem. The parking lot which has a capacity of 200 cars is to be controlled by a PLC system. The sensor S1 and S2 are used to count the car at the entrance and exit. If the number of the cars reaches to 200, red light is lit and the gate arm is closed. The arm stays closed until one or more parking space is available in the lot. The gate arm is controlled by activating/deactivating the gate solenoid (GS).	L3		5

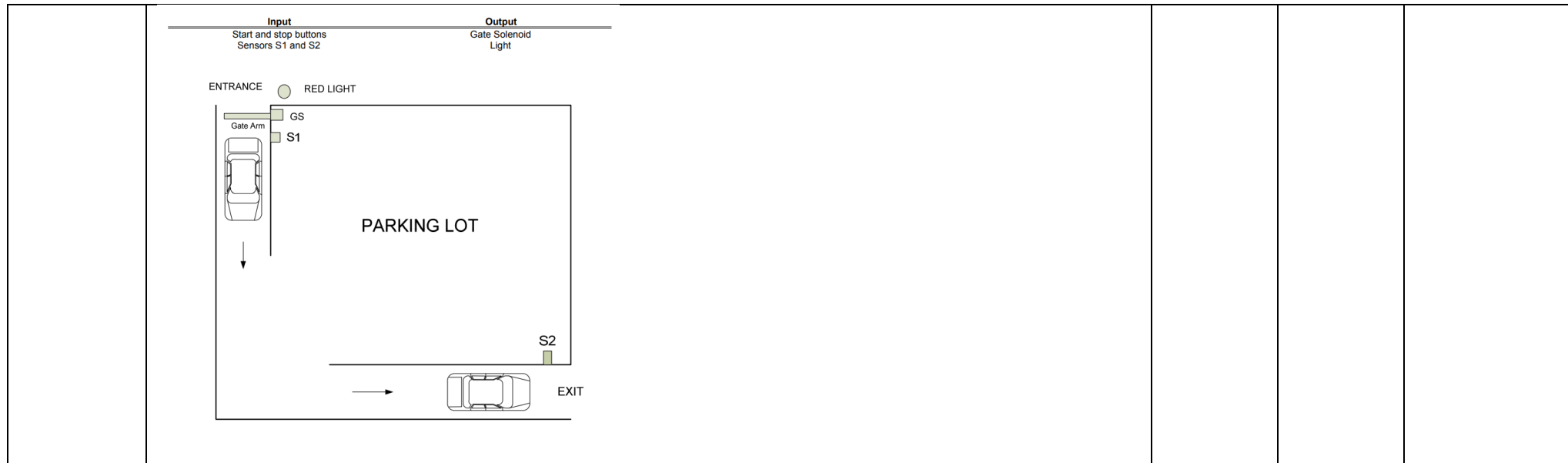

2.a)

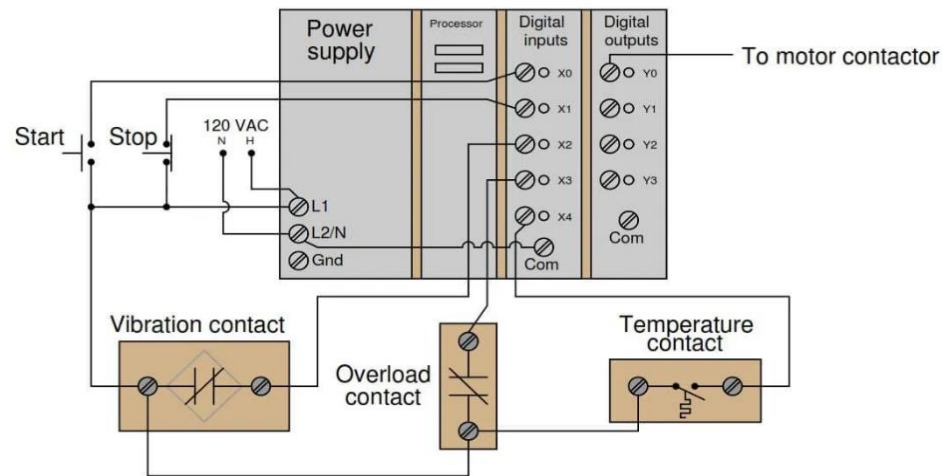

L4

10

This PLC is being used to start and stop an electric motor, and also to shut it down automatically if any of three “shutdown” conditions occur:

- Excessive vibration
- Overcurrent (overload heater contact)
- High winding temperature

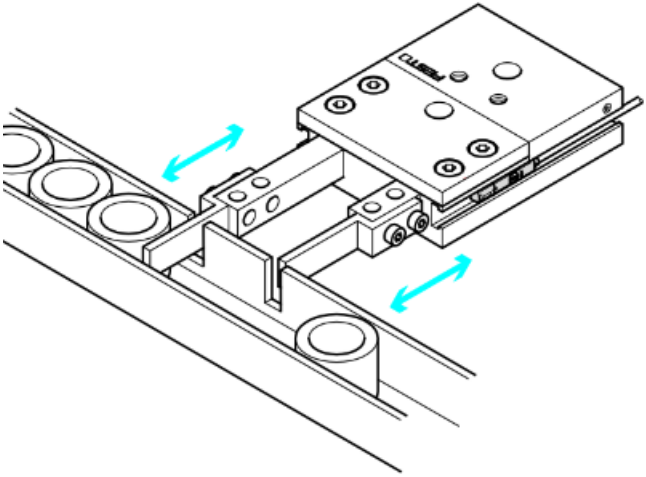
	<p>The status of each shutdown contact is as follows: Vibration contact: closed when okay, opens when vibration becomes excessive Overload contact: closed when okay, opens when overloaded Temperature contact: open when okay, closes when hot Draw a PLC ladder-logic program to start and stop this motor.</p>			
<p>b)</p>	 <p>Work pieces are transported to a processing unit on a conveyor belt. The work pieces have to be separated upstream of the processing unit. The separating cylinder's end positions are monitored using magnetic proximity switches.</p> <ol style="list-style-type: none"> 1. Select a suitable proximity switch for monitoring the end position of a cylinder. 2. Explain terminology from the field of proximity switch technology. 3. Determine whether or not a solenoid valve can be directly actuated by a proximity switch. 	<p>L4</p>		<p>10</p>
Section-2				
<p>3.a)</p>	<p>Testing of PLC yielded following results. Find likely fault in the PLC</p> <ol style="list-style-type: none"> 1. Diagnostic indicators are not showing RED 2. Power supply is OK 3. Field input , outputs and I/O modules Check Ok 4. Program in the PLC memory matches with the master program and all the working environmental conditions are as recommended by the PLC manufacturer. 5. PLC system still doesn't come up even with proper powering 	<p>L4</p>	<p>2</p>	<p>10</p>

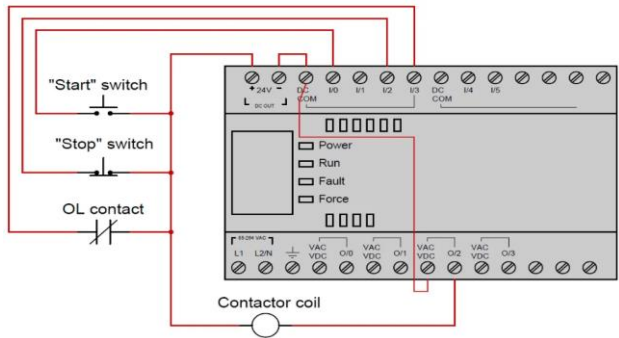
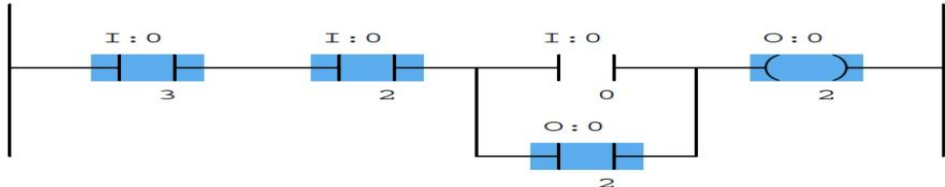
<p>b)</p>  <p>Suppose we have an PLC connected to a pair of pushbutton switches and contactor controlling power to an electric motor as shown in this illustration:</p> <p>This motor control system has a problem, though: the motor refuses to start when the “Start” pushbutton is pressed. Examine the “live” display of the ladder logic program inside this PLC to determine what the problem is:</p> 		L4		10
<p>4.a)</p>	<p>Suggest troubleshooting procedures and corrective actions for PLC system for the following faults</p> <ol style="list-style-type: none"> All LEDs are off ERROR LED is flashing <p>https://www.plctutorialpoint.com/plc-fault-finding-troubleshooting/</p>	L4		10
<p>b)</p>	<p>Suggest troubleshooting procedures and corrective actions for PLC system for the following fault. No abnormality is found with the PLC CPU, its power supply, the I/O modules, and corresponding field I/O devices PLC system is still not working.</p>	L4		10
Section- 3				
<p>5.a)</p>	<p>Why the VFD operated Motor produces more Torque than across the line?</p>	L3	3	5
<p>b)</p>	<p>Suggest possible solutions for following faults/issues in VFD</p> <ol style="list-style-type: none"> VFD starts but will not run 	L3		15

	<ol style="list-style-type: none"> 2. No display 3. Under voltage fault 4. Motor overload fault 5. Overcurrent Fault 			
<p>6.a)</p>	<p>Unfortunately, though, there is something wrong with this system. The pump does not run, regardless of what the operator commands using the touch-screen panel. When you examine the VFD faceplate, you see a few LED indicators lit, but nothing either confirming or denying that power is reaching the motor.</p> <p>Supposing the only test equipment available to you is a digital multimeter (DMM), what diagnostic tests could you perform to identify the location and nature of the system fault?</p>	<p>L4</p>		<p>10</p>
<p>b)</p>	<p>Suggest troubleshooting Procedures and Corrective Actions for servo drive for the following faults</p> <ol style="list-style-type: none"> 1. The servo motor runs faster in one direction than the other 2. Servo motor stalls 3. The LED light is green, but the servo motor doesn't move 4. When the servo motor rotates, the LED light flashes 5. Servo Motor Shuts Off After Reaching High or Full Speed 	<p>L4</p>		<p>10</p>

Section-4				
7	To automate a sorting station 1. Write the process algorithm (step by step procedure/ instructions) 2. Block diagram of system/process diagram 3. Schematic diagram of logic circuit /PLC ladder diagram/ Functional block diagram /Structured list/ instruction list Selection of proper sensors , motors, switches , valves other accessories with specifications	L4	4	20
8	To automate a packaging system 1. Write the process algorithm (step by step procedure/ instructions) 2. Block diagram of system/process diagram 3. Schematic diagram of logic circuit /PLC ladder diagram/ Functional block diagram /Structured list/ instruction list Selection of proper sensors , motors, switches , valves other accessories with specifications	L4		20
Section-5				
9.a)	Explain part of the SCADA system which initiates all most all communications and interface with operator.	L3	5	5
b)	Explain the scenarios where 1. Profibus is preferred over Modbus 2. Modbus is preferred over Profibus	L3		10
c)	Can we replace PLC with RTU? Justify your answer.	L3		5
10.a)	Where HART protocol is used. Why is it called as Hybrid protocol? Compare its data rate and range with other protocols			10
b)	Are alarms indispensable in SCADA systems? Justify your answer.	L3		10

Scheme of Evaluation for SEE 2

Sl. No	Description	Marks
Automate given process		
1	Process algorithm (step by step procedure/ instructions) with Block diagram of system / process diagram	10
2	Schematic diagram of logic Circuit /PLC ladder diagram/ Functional block diagram /Structured list/ instruction list	20
3	PLC Input / Output List	05
4	Power distribution scheme	05
5	Selection of proper sensors, motors, switches, valves other accessories with specifications	10
6	Selection of PLC /HMI with proper specifications	05
7	Proper Input/output connections to PLC	10
8	Simulation of ladder diagram	10
9	Professional practice 1. Safety Electrical power supply and circuit integrity with proper insulation with no bare wires and loose connections, pneumatic , mechanical connections integrity firm , no leaks 2. Usage of proper tools and equipment usage Usage of right tools and methods for electrical connections. Mounted hardware and circuit board properly. No damage to tools and equipment	05
10	Testing and Troubleshooting of automated system	10
11	Results (of fully automated)	10
Total		100

Equipment/software list with Specification for a batch of 20 students

Sl. No.	Particulars	Specification	Quantity
1	PLC Systems with digital I/P, O/P modules and software	12/24v Dc/relay 6 Digital Inputs , 4 Digital Outputs, ethernet card standard micro Sd card integrated webserver	5
2	PLC Systems with analog I/P, O/P modules and software	12/24v Dc/relay 6 Digital Inputs , 4 Digital Outputs, ethernet card standard micro Sd card integrated webserver	2
	HMI with software	7 inch panel, 24 V DC	5
3	Pneumatic kit	Valves , air compressor (minimum capacity) and accessories	1
4	Conveyor belt assembly	Prototype	2
5	PLC control panel	With mounting arrangement for PLC power supply pushbutton switch etc.	2
6	VFD	2HP	2
7	Servo Motor	1.5 Kw	2
8	Raspberry PI Board		5



Government of Karnataka
DEPARTMENT OF COLLEGIATE AND TECHNICAL EDUCATION

Program	Electrical & Electronics Engineering	Semester	5
Course Code	20EE52I	Type of Course L:T:P	Integrated 104:52:312
Specialization	Power Engineering	Credits	24
CIE Marks	240	SEE Marks	160

Introduction: Power engineering, deals with the generation, transmission, distribution, and utilization of electric power, and the electrical apparatus connected to such systems. The power engineering course is taught in Boot camp mode. Boot camp are 12 weeks of intense learning sessions designed to prepare the students for the practical world – ready for either industry or becoming an entrepreneur. Students will be assisted through the course, with development-based assessments to enable progressive learning. Power engineering introduces Smart Grid, Energy auditing, SCADA and IoT. This specialization enables the student to install, commission, test and maintain an EV charging stations. Students are also exposed to power quality issues in Data centers and ways to mitigate them.

Pre-requisite

Before the start of this specialisation course, student shall have prerequisite knowledge gained in the first two years on the following subjects:

1st year – Engineering Mathematics, computer Aided Engineering Graphics, Fundamentals of Electrical and Electronics Engineering and Basics of Electrical power system, Communication Skills, Statistics & Analysis, Basic IT Skills, Project Management skills and Residential wiring.

2nd year- Transformers and Alternators, Transmission and Distribution, Switchgear and Protection, Analog and Digital electronics, Electrical motors, Power electronics, Fundamentals of Automation Technology and Computer Aided Electrical Drawing.

In the third year of study, student shall be applying previous years learning along with specialised field of study into projects and real-world applications.

Course Cohort Owner

A Course Cohort Owner is a faculty from the core discipline, who is fully responsible for one specialised field of study and the cohort of students who have chosen to study that specialised field of study.

Guidelines for Cohort Owner

1. Each Specialized field of study is restricted to a Cohort of 20 students which could include students from other relevant programs.
2. One faculty from the Core Discipline shall be the Cohort Owner, who for teaching and learning in allied disciplines can work with faculty from other disciplines or industry experts.

3. The course shall be delivered in boot camp mode spanning over 12 weeks of study, weekly developmental assessments and culminating in a mini capstone.
4. The industry session shall be addressed by industry subject experts (in contact mode/online / recorded video mode) in the discipline only.
5. The cohort owner shall be responsible to identify experts from the relevant field and organize industry sessions as per schedule.
6. Cohort owner shall plan and accompany the cohort for any industrial visits.
7. Cohort owner shall maintain and document industrial assignments, weekly assessments, practices and mini-project
8. The cohort owner shall coordinate with faculties across programs needed for their course to ensure seamless delivery as per time table
9. The cohort owner along with classroom sessions can augment or use supplemental teaching and learning opportunities including good quality online courses available on platforms like Karnataka LMS, Infosys Springboard, NPTEL, Unacademy, SWAYAM, etc.

Course outcome:

On successful completion of the course, the students will be able to:

C01	Select and demonstrate the appropriate charging methods for a given EV.
C02	Install, test and commission the EV charging station and evaluate the charging capabilities of the EV charging station.
C03	Measure, Monitor, and control power in an electrical utility.
C04	Perform an energy audit of a given building /industry and suggest suitable energy-saving measures.
C05	Analyze the power quality issues in a data center and suggest suitable remedies.

Detailed course plan

Week	C O	P O	Days	1 st session (9am to 1 pm)	L	T	P	2 ND session (1.30pm to 4.30pm)	L	T	P
1	3	1	1	<p>Introduction to power engineering</p> <ul style="list-style-type: none"> • Growth of the Power sector in India and globally. • Role and importance of power sector organization in India • Central sector: NTPC, CEA, power grid, NLDC • Private: Tata Power, Adani, Reliance, ABB, Jindal • State sector: KPC, KPTCL, ESCOM's • Organization structure of the power sector including. - installed capacity India/Karnataka. • Virtual tour of NTPC, Power grid NLDC, Tata Power, Adani, Reliance, ABB, Jindal ,etc., <p>Collect following data and present</p> <ul style="list-style-type: none"> • Category wise (thermal, hydel, nuclear, and renewable) Installed capacity -Indi , Karnataka • Daily generation • Growth of electricity generation in India • Growth of Electricity consumption • (%) Towns where AT&C loss reduced • Transmission Lines (CKm) • Transformation Capacity(MVA) 	1		3	<p>Term: Decarbonization: How Does Decarbonisation Work? Why is Decarbonisation Important? How do we Decarbonise? NetZero: Meaning of NetZero, the difference between NetZero and zero.</p> <p>Sustainability Carbon footprint calculator Calculate your family's carbon footprint. Ref 1b</p> <p>Importance of Power positive Ref 1c</p>	1		2

			<ul style="list-style-type: none"> • Growth of Transformation capacity (MVA) and transmission lines (CKm) 							
3	1	2	<p>Ref 1g</p> <p>Power Transmission:</p> <ul style="list-style-type: none"> • Present power transmission network: <p>Transmission system details of India Collect the following data and present</p> <ul style="list-style-type: none"> • Completed Transmission systems • Upcoming Transmission projects • Transmission systems under construction <p>Ref 1d</p> <p>Entities of power transmission:</p> <ul style="list-style-type: none"> • Central: Power Grid, NLDC • State: KPTCL, SLDC. <p>Power Transmission system development/future plans</p> <ul style="list-style-type: none"> • HVAC transmission • HVDC transmission • Benefits of HVDC transmission <p>Reduction in land for substation – GIS</p> <p>Transmission Loss</p> <p>Power Distribution:</p> <ul style="list-style-type: none"> • HV distribution – Industrial • LV distribution – Irrigation, domestic. • Distribution entities – ESCOM's <p>Distribution loss – AT&C loss</p>	1		3	<p>Regulating Authorities: Role of regulating authorities in power system.</p> <p>Regulating Authorities:</p> <ul style="list-style-type: none"> ❖ Central: CEA, CERC ❖ State: KERC <ul style="list-style-type: none"> • Indian Grid code • Different tariff structure <ul style="list-style-type: none"> • Demonstrate Power system operation • Power/Energy demand (Peak/Non-Peak) • Demonstrate Role of LDC in power system operation. • Power Dispatch – Declaring, scheduling, Un-scheduled Interchange (UI) 	2		1

				<ul style="list-style-type: none"> Billing efficiency and collection efficiency Action Plan for Billing efficiency and collection efficiency Improvement. Problems on AT & C losses <p>Collect following data and present AT & C Loss % of ESCOMS</p> <p>Ref 1f Glossary of key terms: Average Cost of Supply (ACS), Average Revenue Realised (ARR), AT&C losses, Cross-subsidy, DISCOM/ Distribution utility, Energy deficit, Peak deficit, Plant Load Factor (PLF), Power Purchase Agreement (PPA): Smart Grid, Tariff petitions and orders</p>							
	1	3		<p>Design thinking What is design thinking? 5 steps of Design Thinking. Ref:1j Why is design thinking so important? Ref:1k</p>	2		2	<p>Examples of design thinking Ref:1L</p>	1		2
	1	4		Applying Design Thinking to Sustainable Energy. Ref:1M			4	How can 'Design Thinking' help utilities prepare for a new energy future? Ref:1N			3
		5		Developmental Assessment	-	-		Assessment Review and corrective action			3
		6		Industry Class + Assignment	2		3				
Week	C O	P O	Days	1st session (9 am to 1 pm)	L	T	P	2ND session (1.30 pm to 4.30 pm)	L	T	P
2	1	1	1	Peer discussion on Industrial assignment.		4		Fundamentals of electric vehicle charging technology and its grid integration: Key Terminologies used in the EV Ecosystem:	2		1

							<p>Electric Vehicle (EV), Battery Electric Vehicle (BEV), Hybrid Electric Vehicle (HEV), Hybrid Electric Vehicle (HEV), Plug-in Hybrid Electric Vehicle (PHEV), Charging Station/ Electric vehicle Charging Station (EVCS), Charging Point/ Electric Vehicle Supply Equipment (EVSE), Charging Pool, Connector, Charge Point Operator (CPO).</p> <p>Types of Electric vehicles, types of Engines Stakeholders in EV Ecosystem</p> <p>Ref 1 EV cost calculator</p> <ul style="list-style-type: none"> • Home charging calculator • Public charging calculator • Journey cost calculator • Co2 emission calculator • Tax saving calculator • Crude oil saving calculator <p>Ref 1h</p>			
1	4	2	<p>Charging technologies for Electric Vehicles:</p> <ul style="list-style-type: none"> • Classification of EV charging technologies • EV charging infrastructure classification <p>Conductive (Plug-in/Wired) charging:</p> <ul style="list-style-type: none"> • Modes of Charging {IEC 61851 standard} • Charging levels as per IEC 62196, IEC 61851, and SAE J1772 	2		2	<p>Technical Details of EV charger:</p> <ul style="list-style-type: none"> • Electric Vehicle battery charger components. • Block diagram of on-board EV charger, • Demonstrate (Video/ physical) EV charger components • Identify different EV charger components <p>Ref 1</p>	1		2

				<ul style="list-style-type: none"> • Comparison between charging levels • Demonstrate (Video/physical) different EV charging technologies • Demonstrate (Video/physical) different modes of charging. Ref1 						
1	4	3	Converters and control for EV <ul style="list-style-type: none"> • charging: Level 1, Level 2, and Level 3 charging • Block diagram and electronics inside an EVSE • Pilot Wire Communication Standard • Identify charging level (1,2,3) for given electric vehicle (Two-wheeler/Three-wheeler, Car/ Bus) 	2		2	Level 3 charging: <ul style="list-style-type: none"> • Block diagram of DC charging station. • Communication and power flow between EV and EVSE: • DC charging station AC/DC converter and control • DC charging station DC/DC converter and control • Identify different components of the DC charging station 	2		1
1	4	4	<ul style="list-style-type: none"> • Charging speed • Connector Types • Type 1/Yazaki (SAE J1772, IEC 62196-1) • Type 2 (IEC 62196-2) • Combined Charging System (CCS 1) • CHAdeMO • Combined Charging System (CCS 2) • GB/T DC Charger • Tesla Supercharger • Selection of charger for given vehicle type, power rating, and voltage. Ref 2b • Identify different EV charging connectors. 	1		3	EV Wireless charging standards, <ul style="list-style-type: none"> • Battery specifications of different EV segments. Ref 2a Battery swapping <ul style="list-style-type: none"> • Types • Battery swapping station and components Ref1 <ul style="list-style-type: none"> • Selection of AC charger type-1, type -2, and type -3 • Selection of DC charger connector GB/T, CHAdeMO, CCS-1, and CSS-2 • Selection sizing of Charger connector cable Technical specification and features of DC chargers <ul style="list-style-type: none"> • DC charger 30KW 	1		2

				<p>The Indian standards of charging connectors are derived from the international standards</p> <ul style="list-style-type: none"> • Bharat AC-001 • Bharat DC 001 <p>Practical conductive charging power curves.</p> <p>Wireless Charging:</p> <ul style="list-style-type: none"> • Inductive WPT: Block diagram of Inductive wireless power transfer • Capacitive WPT: Block diagram of Capacitive wireless power transfer <p>Ref 1</p> <ul style="list-style-type: none"> • Demonstrate (Video) Inductive WPT • Demonstrate (Video) capacitive WPT <p>Ref 1a</p>				<ul style="list-style-type: none"> • DC quick charger 100kW <p>Ref 2c</p>			
			5	Developmental Assessment	-	-		Assessment Review and corrective action			3
			6	Industry Class + Assignment	2		3				
3	1	1	1	Peer discussion on Industrial assignment.		4		<p>Standards for EV Charging International Standards:</p> <ul style="list-style-type: none"> • IEC 61851, • SAEJ1772, • IEC 61980, • SAE J1773, • SAE J2954, • GB/T 20234 <p>Plug, Connector, And Socket Standard:</p> <ul style="list-style-type: none"> • IEC 62196 	2		1

							<ul style="list-style-type: none"> Sections in IEC 62196 standard Miscellaneous: EC 60364, SAEJ2293, SAEJ2836, SAEJ2931, SAEJ2954, IEEE1547, NFPA 70, SAEJ2836 			
1	1,4	2	<p>Indian Standards: AIS 138 part 1: Electric vehicle conductive AC charging: AC slow charging:</p> <ul style="list-style-type: none"> AC slow charging with a separate charger AC slow charging with an On-board charger On-board charger with fixed cable Demonstrate AC slow charging method <p>AC fast charging mode</p> <ul style="list-style-type: none"> AC fast charging with free cable AC fast charging with fixed cable Mandatory and optional safety functions while AC conductive charging Pin information of IEC 60309 and IEC 62196 Connector- IEC 60309 Full form of connector pins in IEC 60309 Connector- IEC 62196 Full form of connector pins in IEC 62196 	2	2	<p>Ref 1</p> <p>Charging protocols for EV charging:</p> <ul style="list-style-type: none"> CHArge de MOve (CHAdeMO) Protocol, Tesla Charging Protocol, Diagram of Tesla supercharger connector Combined Charging System (CCS) <ul style="list-style-type: none"> -Connection pins in CCS1 connector -Connection pins in the CCS2 connector Type 2 AC charging <ul style="list-style-type: none"> -IEC type-2 connector Bharat Charging Standards <ul style="list-style-type: none"> -Bharat AC 001 - Bharat DC 001 <ul style="list-style-type: none"> Identify type 1 plug and socket Identify type male 2 plug and socket Type 2 Female Plug & Socket <p>Ref1</p> <p>DC charging cable</p> <p>When To Use AC And DC Charging for Charge Electric Vehicle?</p> <p>Ref 4</p> <p>Ref 2</p>	2		1	

			<ul style="list-style-type: none"> • Cable assemblies for AC slow and fast conductive charging • Demonstrate AC Fast charging method <p>AIS 138 part 2: Electric vehicle conductive DC charging system</p> <ul style="list-style-type: none"> • Types of EVSE <p>Plug, Socket, Connector:</p> <ul style="list-style-type: none"> • IS 17017 part 2/ section 2, • IS 17017 part 2/ section 3, • Safety Standards. <p>Ref 1 Ref 2 How to choose the type of plug for a charging Type1 and type2 cables Choosing right cable for your car Ref 3</p>						
1	1,4	3	<p>Safety Standards of Electric Vehicle Charging Station: The safety aspect of charging station</p> <ul style="list-style-type: none"> • Electrical safety • Functional safety • Battery charging safety • Maintenance and operation safety. <p>Setting up an EV charging station</p> <ul style="list-style-type: none"> • What is a Charging Station? • Working of Charging Station. • Components of Charging Station. • Types of Charging Station. <p>Ref 5</p> <ul style="list-style-type: none"> • Classification of EV charging infrastructure 	2	2	<p>Setting up an EV charging station</p> <ul style="list-style-type: none"> • What is a Charging Station? • Working of Charging Station. • Components of Charging Station. • Types of Charging Station. <p>Ref 5</p> <ul style="list-style-type: none"> • Classification of EV charging infrastructure • Policy-making and regulatory authorities <p>Ref 6</p> <ul style="list-style-type: none"> • Identify components of the charging station • Demonstrate working of charging station 	1		2

				<ul style="list-style-type: none"> Policy-making and regulatory authorities <p>Ref 6 Assessing Charging demand :</p> <ul style="list-style-type: none"> Steps for the EV charging demand assessment and charging infrastructure estimation. Demand-based target setting for EV charging infrastructure in your city (Bengaluru) <p>Ref 6</p>						
1	1,4	4	<p>Arranging for electricity supply for charging Ref 6 Case-based demonstration: An EV owner has identified a location for setting up a standalone charging facility and wants to install two 50 kW chargers, three 7 kW chargers, and a 9-unit stack battery charging system. After consulting the DISCOM, it is found that the nearby DT has available capacity to support an additional load of 48 kW, beyond which its capacity would need to be augmented. Moreover, the supply code stipulates 7 kW and 65 kW as the maximum sanctioned load limits for single-phase LT and three phase LT electricity connections, respectively. What is the optimal connection type and configuration for the charging facility? Ref 6</p>			4	<ul style="list-style-type: none"> Identify Charging options for various vehicle categories Government guidelines for Setting EV Charging Stations <p>Ref 11</p> <ul style="list-style-type: none"> State Government Policy <p>Ref 12</p> <p>SMART EV CHARGING</p> <ul style="list-style-type: none"> Back-end architecture for smart charging Communication protocols for smart charging <p>Ref 6 Ref 2 Integrating EV charging in grid planning</p> <ul style="list-style-type: none"> Impact of EV charging on power demand <p>Ref 6</p> <ul style="list-style-type: none"> Impact of EVs on the Distribution Feeder EV Load Impacts on Electricity Generation Adequacy 	1		2

				<ul style="list-style-type: none"> How to set up an EV charging station Ref 7 <ul style="list-style-type: none"> Minimum requirements of public charging Infrastructure (PCI) Benefits of setting up an Electric car charge station. Ref 8 Cost Estimates for a Typical Public Charging Station (PCS) Ref 9 Ref 10				<ul style="list-style-type: none"> EV Load Impacts on Distribution Grid Equipment EV Load Impact on Power Quality Ref 2 <ul style="list-style-type: none"> Demonstrate impact of EV on Distribution feeder . Demonstrate impact of EV on Power Quality 			
			5	CIE 1- Written and practice test	-	-	-	Assessment Review and corrective action			3
			6	Industry Class + Assignment	2		3				

4	2	4	1	Peer discussion on Industrial assignment.		4		Preparation for installation <ul style="list-style-type: none"> Employ practice of inspecting the site for all requirements for the erection and installation of an EV charging station. Demonstrate the unpacking of the EV charging machine and checking for the presence and functionality of all components, like the transformer, electric kiosks, lines/cables, and associated equipment. Determine the appropriate length of the charging cable and circuit breaker based on-site, charging station, and customer requirements 			3
	2	4	2	Erection of EV charging station	2		2	<ul style="list-style-type: none"> Demonstrate the process of installing conduits for carrying electrical wires, and cables from 			3

				<ul style="list-style-type: none"> List the various types of electrical sources/facilities for energizing the charging station. Explain the process of cabling from electrical facilities such as DISCOM utility, micro-grid systems, solar panels, etc. to the place of installation of the charging station. Discuss the importance of putting identifiable marks on the civil foundation for charging station erection. 				<p>nearest source/facility to the charging station.</p> <ul style="list-style-type: none"> Assign markings on the civil foundation for charging station erection after taking measurements. 			
2	4	3	<p>Erection of EV charging station</p> <ul style="list-style-type: none"> Describe the importance of manufacturer guidelines in unpacking the EV charging station. Detail the technique to be followed to ensure proper erection and positioning of the charging station. Discuss the factors to decide the number of rectifiers to be installed in the charging station. Explain the considerations for a number of charging guns at the EV charging station. 			4	<ul style="list-style-type: none"> Demonstrate the fixing of the EV machine on the civil foundation while ensuring a firm grip. Employ operating of appropriate tools and equipment such as drilling machine, screwdriver set, socket wrench, hammer, washers, nuts; various types of mounting and insertion tools etc. as per the type of task to be performed pertaining to EV charging station installation. 			3	
2	4	4	<p>Installation of EV charging station</p> <ul style="list-style-type: none"> Discuss the relevant IS and IEC standards applicable to the EV charging station installation. State the importance of disconnecting the power 	2		2	<p>Installation of EV charging station</p> <ul style="list-style-type: none"> Demonstrate the installation of a rectifiers for each charging guns in the EV charging station. Demonstrate the installation of earth protection system and AC/DC 			3	

				<p>supply connections before installation.</p> <ul style="list-style-type: none"> Elaborate on the technique to connect the power supply to the main switches and/or installation blocks. State the importance of residual current device in an EV charging station Explain the various types of cable routing techniques such as surface cable routing, and flush-type cable routing within a charging station. Discuss the purpose and installation procedure for the software and communication protocols. Explain the various types of protection to be provided to the charging such as weather protection, protection against voltage fluctuations, safety tests, etc. 				<p>power modules in the EV charging station in line with IS and IEC standards applicable to EV charging station installation.</p> <ul style="list-style-type: none"> Demonstrate the process of installing a residual current device (RCD) or fault current circuit breaker in compliance with the specifications of the charging station. <p>Installation of EV charging station</p> <ul style="list-style-type: none"> Employ configuring of password authentication and licensing software in the charging station. Demonstrate the installation of the appropriate protocol for EV charging, such as Combined Charging System (CCS), GB/T, CHAdeMO (CHArge de Move), AC Charging etc. Employ proper procedure for connecting and positioning the modem to the charging station to ensure effective GSM/CDMA connectivity. 			
			5	Developmental Assessment	-	-		Assessment Review and corrective action			3
			6	Industry Class + Assignment	2		3				
5	2	4	1	Peer discussion on Industrial assignment.	-	4	-	Testing the charging station <ul style="list-style-type: none"> List the various types of tests that are performed to test the EV charging station. 	1		2

							<ul style="list-style-type: none"> • Explain the process to be followed to conduct various types of tests pertaining to the commissioning of an EV charging station. • State the key considerations to check the electrical connections for the charging station. • Elaborate on the technique for measurement of the voltage drop between various parts of the charging station. • Describe the steps to perform calculations for evaluating charging station characteristics and capabilities 			
2	4	2	Testing the charging station <ul style="list-style-type: none"> • Perform earthing tests following industry rules and regulations and standard work practices. • Test the connections of the conductive parts with the supply voltage source as per standard practice. 			4	<ul style="list-style-type: none"> • Conduct tests to check for electrical continuity between exposed conductive parts and the earth circuit. • Apply the technique of measuring the voltage drop between the exposed conductive part and the earthing terminal of the charging station. 			3
2	4	3	Commissioning of EV charging station <ul style="list-style-type: none"> • Commissioning the charging station • Explain the procedure to rectify faults and equipment malfunction pertaining to the commissioning of the charging station. • Describe the need for modifications in the existing systems and installed devices. • State the importance of the installation and 	2			<ul style="list-style-type: none"> • Demonstrate how to deal with equipment malfunction and rectify faults during the commissioning process. • Employ the process of modifying the existing systems and installing electrical devices as per requirements and test results. • Demonstrate the process to document backups, manuals, logs, etc. as per work requirements. 			3

			<p>commissioning certificate in the work process.</p> <ul style="list-style-type: none"> Explain the importance of ensuring that the site is cleared of all (electrical) debris, cleaned, and safe for people before leaving 							
2	4	4	<p>Grid Integration of EVs and its Impacts</p> <ul style="list-style-type: none"> Voltage Stability Issues. Phase Imbalance Increase in Peak Load Overloading, Power Losses. <p>Power Quality: Conductor losses, Neutral Conductor, Motors and Generators, Transformers, Circuit Breakers and Fuses, Flicker:</p> <p>Ref 1 and Ref 2</p> <p>Grid Support from EVs</p> <p>EV charger application</p> <ul style="list-style-type: none"> Primary and secondary applications <p>Concept of Vehicle2X System</p> <ul style="list-style-type: none"> Application of V2X <p>Demonstrate</p> <ul style="list-style-type: none"> Vehicle to Grid(V2G) <p>Ref 13</p> <ul style="list-style-type: none"> Vehicle to Home <p>Ref 14</p> <p>Utilization of EVs for better RE Grid Integration</p> <p>Ref 2</p>	2		2	<ul style="list-style-type: none"> Vehicle to grid simulation using simulation software Simulate/Develop a battery storage system using software/tools 			3
		5	CIE 2- Written and practice test	-	-		Assessment Review and corrective action			3
		6	Industry Class + Assignment	2		3				

--	--	--	--	--	--	--	--	--	--	--	--

Week	C O	P O	Days	1 st session (9 am to 1 pm)	L	T	P	2 ND session (1.30pm to 4.30 pm)	L	T	P
6	3	1	1	Peer discussion on Industrial assignment.		4		Introduction to SCADA: <ul style="list-style-type: none"> • What is SCADA? • SCADA SYSTEMS • Evolution of SCADA • Objective of SCADA. • Benefits of SCADA • Functions of SCADA: • SCADA APPLICATIONS • Usage of SCADA, • Real-Time Monitoring and Control using SCADA Ref 15	3		
	3	1	2	SCADA HARDWARE: <ul style="list-style-type: none"> • SCADA Hardware Functions, • Remote Terminal Units (RTU): RTU Hardware: A typical single-board RTU. • Hardware functionality in an RTU, RTU Software functions • Basic operation: RTU Standards. • Difference between PLC and RTU • Features of SCADA Ref 15 Demonstrate the difference between PLC and RTU Ref 16 <ul style="list-style-type: none"> • Demonstrate the power measurement using a multifunction transducer. 	2		2	SOFTWARE AND PROTOCOLS. <ul style="list-style-type: none"> • ISO MODEL, • DNP3 Protocol: Important Features of DNP3. • IEC60870 PROTOCOL The two widely used protocols for SCADA Applications : <ul style="list-style-type: none"> • HDLC (High-Level Data Link Control) • MODBUS The widely-used open software for SCADA systems : <ul style="list-style-type: none"> • Citect and Wonderware. Ref 15	2		1

				Ref 17 <ul style="list-style-type: none"> Necessity of Intelligent electronic devices in power regulation. Ref 18							
	3	1	3	Power system automation: <ul style="list-style-type: none"> Benefits of power system automation, Structure of Power System Automation Architecture for power system automation. Classification of Power system Automation: <ul style="list-style-type: none"> Substation Automation Distribution Automation Ref 15 Demonstrate <ul style="list-style-type: none"> Substation Automation Distribution Automation 	2		2	Implementation of power system automation and protection using SCADA: <ul style="list-style-type: none"> Hardware Development. Software Programming Simulation SCADA-Based Model for Automation and Digital Protection Ref 15			3
	3	4	4	<ul style="list-style-type: none"> Simple Digital System implementation in SCADA software. Simple analog System implementation in SCADA software 			4	Create SCADA Animation in SCADA software			3
			5	Developmental Assessment	-	-		Assessment Review and corrective action			3
			6	Industry Class + Assignment	2		3				
7	3	1	1	Peer discussion on Industrial assignment.		4		Introduction smart Grid-1 <ul style="list-style-type: none"> Meaning of smart Grid Smart Grid - Analogy with Human Body Ref 19 <ul style="list-style-type: none"> DRIVERS FOR SMART GRID 	2		1

							<ul style="list-style-type: none"> • Components of the electrical grid • History of the power grid • Evolution of power grid • Regulatory the authorities of the Indian energy sector • impact of the electrical grid • key figures of our country • Indian power scenario • Factors affecting the performance the of existing grid • What makes grid smart • smart grid conceptual model • Smart grid definition • Duties of smart grid • smart grid architecture • smart grid components <p>Ref 20 Why do we need a smart grid Is the smart grid a “Green grid”</p> <p>Ref 20a Virtual tour on Smart grid</p> <p>Ref 20b</p>			
3	1	2	<p>Introduction smart Grid-2</p> <ul style="list-style-type: none"> • Power generation • Distributed generation • Transmission • Distribution • Smart information • Smart metering • Sensors • information management • smart communication • smart communication in the smart grid • Smart management 	2		2	<p>The architecture of smart grid system</p> <ul style="list-style-type: none"> • Grid layout • customer domain • market domain. • service provider domain • operation domain • bulk generation domain • transmission domain <p>Ref 20 Tariff design for smart grid consumers</p> <ul style="list-style-type: none"> • Time of day (TOD) / time of use tariff (TOU) • Critical peak pricing (CPP) 	2		1

			<ul style="list-style-type: none"> • Smart protection system • challenges in smart protection system • Smart grid standards • Barriers to smart grid technologies <p>Ref 20 Demonstration of above Grid components</p>				<ul style="list-style-type: none"> • Real time pricing • Return of smart grid investment through surcharges on consumers who are benefitted <p>Ref16 Demonstration of TOD/TOU tariff</p>			
3	1	3	<p>Standards for the smart grid system</p> <ul style="list-style-type: none"> • Smart grid standards • Classification of Smart grid standards <p>Ref 20 Use cases, lessons learned – pilot project experiences</p> <ul style="list-style-type: none"> • The CESC, Mysore Smart grid pilot Project • Gujrat smart grid pilot project. • Electricity department, government of Puducherry <p>REF19</p>	2		2	<p>Elements and Technologies of smart grid system – I</p> <ul style="list-style-type: none"> • AMI (Advance Metering Infrastructure) • Smart meter –Block diagram • Benefits of Smart Meter • smart meter measurements • networking for AMI • Components of AMI • DA (Distribution Automation) <p>Ref 20 Ref 19 Smart grid of tomorrow</p> <p>Ref 21 Demonstration of AMI</p>	2		1
3	4	4	<p>Elements and Technologies of Smart Grid System- II</p> <ul style="list-style-type: none"> • SCADA <p>Smart Metering</p> <ul style="list-style-type: none"> • compare conventional and smart metering • Functional diagram of smart metering • signal acquisition • signal conditioning • ADC 	2		2	<p>Simulation of a sample smart grid</p> <p>Ref 23</p>			3

				<ul style="list-style-type: none"> • Computation • Memory • Communication Ref 20 Installation of smart meters Testing of smart meters Ref 22							
	3		5	CIE 3 Written and practice test				Assessment Review and corrective action			3
			6	Industry Class + Assignment	2		3				
8	3	1	1	Peer discussion on Industrial assignment.	-	4	-	Introduction to IoT <ul style="list-style-type: none"> • main components used in IoT • ways of building IoT • Characteristics of IoT • Modern Applications Ref 24 a and Ref 24 b	1		2
	3	4	2	<ul style="list-style-type: none"> • Communication devices in IoT Needs for setting up IoT environment for basic applications <ol style="list-style-type: none"> 1. Choosing a platform for IoT development <ul style="list-style-type: none"> • AWS IoT: (Amazon Web Services) • Microsoft Azure IoT: <ol style="list-style-type: none"> 2. Choosing IoT hardware processor: <ul style="list-style-type: none"> • Arduino -Set up – procedure, Advantages: • Raspberry Pi - Set up – procedure, Advantages: • Need to use Bluetooth beacons 	1		3	<ol style="list-style-type: none"> 1. Simulate and Test blinking of LED using Arduino. 2. Simulate and test the dc motor using Arduino <ol style="list-style-type: none"> (i) clockwise & anti-clockwise rotation using Arduino. (ii) Speed control of dc motor using PWM 3. Measure voltage, current, and resistance using Arduino. 			3

			Ref 25							
3	4	3	Introduction to NODE MCU ESP8266 (WIFI module) Ref 26 IoT-based Smart Energy Meter using NodeMCU ESP8266 Ref 27 a and Ref 27 b	1		3	Automate system to control appliances from anywhere through the internet. Ref 28			3
		4	What is Raspberry pi and why is it important for IOT Ref 29 IoT-based Smart Energy Meter using Raspberry PI Raspberry PI <ul style="list-style-type: none">Use of Raspberry PI in IOT Ref 30	1		3	Applying IoT technologies in the Electric Power Industry <ul style="list-style-type: none">IoT applications: Energy GenerationIoT applications: energy transmissionIoT applications: Energy Consumption Ref 31 IoT-Based Energy Management System Ref 32 Benefits of Smart Energy Management using IoT (Internet of Things) Ref 33a			3
		5	Developmental Assessment	-	-		Assessment Review and corrective action			3
		6	Industry Class + Assignment	2		3				

9	4	1	1	Peer discussion on Industrial assignment.		4	HVDS: High Voltage Distribution system <ul style="list-style-type: none">Cost-benefit Analysis of HVDSImplementation of HVDS ESCOMS in Karnataka Demonstration of HVDS system. Ref33b	1		2
----------	---	---	---	--	--	---	---	---	--	---

	4	1	2	<ul style="list-style-type: none"> Loss reduction by improving the ratio of HT/LT line in Electrical Distribution System <p>High Voltage Distribution System (HVDS)-An Alternate for Improvement of Voltage Drop Profile</p> <ul style="list-style-type: none"> Open access in T &D Electricity Act Provisions <p>Ref33b</p>	2		2	<ul style="list-style-type: none"> Power Trading in Multi buyer and multi-seller environment Availability-based tariff concept and importance Balancing and settlement mechanism <p>Demonstration of Power trading</p>	1		2
	4	1	3	<ul style="list-style-type: none"> Power trading rules in the changed scenario <p>Role of Regulatory Commissions</p> <ul style="list-style-type: none"> Open Access challenges for Power Market Power Exchanges and their functioning. Market Based economic Dispatch (MBED) Green Day Ahead Market (GDAM) <p>Collect the following data and present</p> <ul style="list-style-type: none"> Exchange price Power purchased from the exchange State demand met Shortage in MW <p>Ref 1e</p>	1		3	<p>Demand-side management</p> <ul style="list-style-type: none"> Introduction Types of DSM program Benefits of DSM <p>DSM techniques</p> <ul style="list-style-type: none"> load clipping load shifting, valley filling Load Reduction Strategic Load Growth Flexible Load Shape <p>Ref 34a, 34b, 34c Demonstration of different DSM techniques</p> <p>Demand-side management Ref 35</p>	2		1
	4	2	4	<ul style="list-style-type: none"> Agriculture side Demand-side Management <p>Ref 36 a and Ref 36 b</p> <ul style="list-style-type: none"> Municipal demand side management (MuDSM): <p>Ref 37</p>	1		3	<p>For a residential building suggest suitable energy efficient appliances for lighting, refrigeration, heating, and cooling.</p> <ul style="list-style-type: none"> Calculate energy saving Per annum using those energy-efficient appliances. Saving of Co2 emission 			3

			Demonstrate Ongoing DSM projects in Karnataka Ref 38 Demonstrate DSM measures by Distribution Companies (DISCOMs) Ref 39					<ul style="list-style-type: none"> • Saving coal • Saving water 			
		5	CIE 4 Written and practice test					Assessment Review and corrective action			3
		6	Industry Class + Assignment	2		3					
10	4	1	1	Peer discussion on Industrial assignment.		4		ENERGY MANAGEMENT AND AUDIT <ul style="list-style-type: none"> • Definition & Objectives of Energy Management • Need for Energy Audit • Types of energy audit • Preliminary Energy Audit Methodology • Detailed Energy Audit Methodology Ref 40	2		1
	4	1,2	2	Ten Steps Methodology for Detailed Energy Audit Phase I -Pre Audit Phase Activities Phase II- Detailed Energy Audit Activities Ref 40	3		1	<ul style="list-style-type: none"> • Draw process flow diagram and list process steps; identify waste streams and obvious energy wastage Example: A flowchart of Penicillin-G manufacturing • Identification of Energy Conservation Opportunities • Technical and Economic feasibility Ref 40	3		
	4	4	3	<ul style="list-style-type: none"> • Classification of Energy Conservation Measures Energy Audit Reporting Format <ul style="list-style-type: none"> • Understanding Energy Costs 	2		2	Energy Audit Instruments Demonstrate use of following <ul style="list-style-type: none"> • Electrical Measuring Instruments: • Combustion analyzer: • Fuel Efficiency Monitor: • Fyrite: • Contact thermometer: • Infrared Thermometer: 	1		2

			<ul style="list-style-type: none"> • Benchmarking and Energy Performance • Matching Energy Usage to Requirements • Best Operating Practices- lighting <p>Common monitorable parameters and performance assessment</p> <ul style="list-style-type: none"> • Motors • Transformers • Lighting system • Power generator set • Harmonic distribution at common coupling point(PCC) <p>(https://beeindia.gov.in/content/publications-0) EC guidelines</p> <p>Explain motor load survey? Suggest Energy Conservation Measures for the different motor loading. Problems on energy audit</p>				<ul style="list-style-type: none"> • Pitot Tube and manometer: • Speed Measurements: • Leak Detectors: • Lux meters: • Ultrasonic flow meter • TDS meter <p>Ref 40 Energy Audit in ESCOMS</p> <ul style="list-style-type: none"> • 11 kV lines • Town audit • DTC wise audit <p>EESL (Energy efficiency services Limited) Mobile App Present achievements of various EESL schemes</p> <ul style="list-style-type: none"> • Energy saved per year (Mus) • Cost saving per year • Avoided peak demand in MW • Co2 reduction per year (million tonnes) <p>Ref 41 Calculate the annual energy savings and simple payback from replacing standard Existing motor with energy efficient motor versus rewinding the existing motor.</p>			
4	2,4	4	Perform energy audit of nearby Industry/Apartment/Commercial Complex/Malls and prepare			4	Perform energy audit of nearby Industry/Apartment/Commercial Complex/Malls and prepare a report as per standard format			3

			a report as per standard format							
		5	Developmental Assessment	-	-		Assessment Review and corrective action			3
		6	Industry Class + Assignment	2		3				

11	5	1	1	Peer discussion on Industrial assignment.	-	4	-	Introduction to Data Centre <ul style="list-style-type: none"> Datacenter's growth trend Present scenario and future growth of Datacenter's in India Sources of Datacenter's power consumption. Classification of Datacenter's Based on the Maximum IT Load Typical Datacenter's power consumption architecture Ref 42	2		1
	5	2,4	2	Electrical requirements of Datacentres <ul style="list-style-type: none"> Power flow in a Data centers Calculating Total Power Requirements for Data Centers Major components of electrical infrastructure Diesel Generator <ul style="list-style-type: none"> Selection of DG set for Data centers application Demonstrate Some energy-saving measures for DG sets Transformer is the gateway for the power to the Data centre	2		2	Transfer switch arrangement: Automatic Transfer Switches (ATS) <ul style="list-style-type: none"> Schematic of Automatic Transfer switch Arrangement Demonstration of ATS Ref 42	1		2

			<ul style="list-style-type: none"> • Harmonics and K - Factor transformer • Harmonics and K - Factor transformer Ref 42							
5	1,4	3	<p>Transient Voltage Surge Suppressor (TVSS)</p> <ul style="list-style-type: none"> • TVSS Ratings • TVSS specification • The selection of surge suppressor • TVSS Selection Chart • Benefits of Transient Voltage Surge Suppressor <p>Demonstrate different TVSS</p> Ref 42	1		3	<p>Uninterrupted Power Supply (UPS) System:</p> <ul style="list-style-type: none"> • Typical Schematic diagram of Uninterruptible Power Supply • Loading versus. Efficiency Curve for a UPS • Comparison of the efficiency curves vs IT load for two different Data centers <p>UPS Topologies</p> <ul style="list-style-type: none"> • Offline UPS: (Passive standby) • Line interactive • Online double conversion • Selection criteria • UPS configuration • High availability power system Ref 42 Demonstrate Modular/compact ups used in Data centres Ref 42c	2		1
5	4	4	<p>Determination of availability</p> <ul style="list-style-type: none"> • MTBF (Mean time before failure) • MTTR (Mean Time between Repair) <p>Power Distribution Unit (PDU)</p> <ul style="list-style-type: none"> • Diagram of Power Distribution from the UPS to the IT load through the PDU 	2		2	<p>Advanced power strip</p> <ul style="list-style-type: none"> • Benefits of Advanced Power Strips • Energy-saving opportunities in Electrical systems- • Demonstrate use of Advanced power strip Ref 42	1		2

				Modular Power Distribution Unit (PDU) <ul style="list-style-type: none"> • Demonstrate Modular Power Distribution Unit (PDU) • An ideal power distribution system attributes: • Schematic of Modular Power Distribution System Static switch: <ul style="list-style-type: none"> • Static Transfer switches • Benefits of STS • Demonstrate working of STS (Static Transfer switches) Ref 42						
			5	CIE 5 Written and practice test	-	-		Assessment Review and corrective action		3
			6	Industry Class + Assignment	2		3			
12	5		1	Peer discussion on Industrial assignment.	-	4	-	Substation equipment needed to power up the data center: Ref 42 a Cost of Data Centre Outages Ref 42 b	2	1
	5	1,4	2	Power quality Understanding the Importance of Power Quality in the Data Centre <ul style="list-style-type: none"> • What is Power Quality • Need for power quality Power Quality Parameters <ul style="list-style-type: none"> • Reactive power and power factor • Total harmonic distortion (THD) Potential Impact of following parameters in the data center <ul style="list-style-type: none"> • Transients 	1		3	Measure and analyse power quality parameters using a power analyser for the following <ul style="list-style-type: none"> • Induction motor on load • UPS supplying power to computers Remedial measures to mitigate power quality issues. Ref 43 power quality meters Ref 44a &b		3

			<ul style="list-style-type: none"> • Interruptions • Sag / Under voltage • Swell / Over voltage • Waveform distortion • Voltage fluctuations • Frequency variations <p>Understanding the Importance of Power Quality in the Data Center Ref 45</p>							
5	1,2	3	<p>Medium-Voltage Circuit Breaker-Type Automatic Transfer Switches and Bypass/Isolation Switches Fail-Safe vs. Maintenance Bypass Switches: A Comparison Ref 46</p> <ul style="list-style-type: none"> • Standard Critical Power Distribution Unit • Standard and Intelligent Critical CPDUs • Power Usage Effectiveness (PUE) <p>Ref 47 Recommended practice for electrical preventative maintenance Ref 48</p>	1		2	<p>Ways Data Centres Can Improve Energy Efficiency Ref 49 Datacenter energy management Ref 50 Best practices for energy management Ref 51 Energy-efficient guidelines and best practices in energy management in Indian datacentres Ref 52</p>	1		2
5	2,4	4	<p>Case studies Case study 1: Power quality improvement in a data centre by installing harmonic filters Case study 2 Energy efficiency improvement in lighting system by replacing</p>			4	<p>Water consumption in data centers Ref 54 Estimating a data center's carbon footprint Ref 55 Data centers in Bangalore Ref 56</p>			3

				fluorescent lamps with light-emitting diode (LED) lamps Case study 3: Energy efficiency improvement in ups systems by loading optimization Ref 42 Data center case study 4 Ref 53							
			5	Developmental Assessment	-	-		Assessment Review and corrective action			3
			6	Industry Class + Assignment	2		3				
Week	C O	P O	Days	1st session (9am to 1 pm)	L	T	P	2ND session (1.30pm to 4.30pm)	L	T	P
13	1,2, 3,4, 5	2,3, 4		Internship a) Secondary research on various industries and their operations to identify at least 3 companies along with the areas of work interest and develop an internship plan that clearly highlights expectations from the industry during the internship. b) Design and develop a cover letter for an internship request to all 3 identified companies and the resume to be submitted to potential companies. c) Prepare for an internship interview to highlight your interests, areas of study, career aspirations and personnel competence – including the areas of learning you expect to learn during internship	2	4	2	Project a) Identification of the problem statement (from at least 3 known problems) the students would like to work as part of the project – either as provided by faculty or as identified by the student. Document the impact the project will have from a technical, social and business perspective. b) Design and develop the project solution or methodology to be used to solve at least one of the problems identified. Prepare a project plan that will include a schedule, WBS, Budget and known risks along with strategies to mitigate them to ensure the project achieves the desired outcome.		4	10

References

Sl No	Description	
1	Fundamentals -of Electric Vehicle Charging Technology- and-its-Grid- Integration	e-amrit.niti.gov.in > assets > admin
1 a	Wireless charging	https://in.mathworks.com/company/mathworks-stories/wireless-charging-for-electricvehicles.html?s_tid=srchtitle_electric%20vehicle_1
1 b	Carbon footprint calculator	https://www.tatapower.com/sustainability/sustainability-initiatives/customer/calculate-carbon-footprints.aspx
1 c	Importance of Power positive	https://www.indoasiancommodities.com/2022/03/03/kochi-airport-to-become-power-positive-with-its-new-solar-plant/ https://energy.economictimes.indiatimes.com/news/renewable/airport-in-kochi-to-become-power-positive-with-new-solar-plant-from-march-6/89882448
1 d	Transmission system details of India	http://www.tarang.website/welcome
1 e	Karnataka state data (Power details)	http://vidyutpravah.in/state-data/karnataka
1 f	AT &C Loss %	https://www.uday.gov.in/home.php
1 g	National power portal	https://npp.gov.in/dashBoard/trans-map-dashboard
1 h	EV cost calculator	https://e-amrit.niti.gov.in/co2-calculator

1j	Design thinking	https://careerfoundry.com/en/blog/ux-design/design-thinking-examples/ https://www.interaction-design.org/literature/topics/design-thinking https://www.applify.com.sg/blog/design-thinking-from-empathy-to-end-product/ https://infyspringboard.onwingspan.com/web/en/viewer/video/lex_auth_012797092157964288580_shared?collectionId=lex_auth_0127858770650972161567_shared&collectionType=Course&pathId=lex_auth_0128111895288627201003_shared
1k	why is design thinking so important?	https://growthnatives.com/why-is-design-thinking-so-important/
1L	Examples of design thinking	https://careerfoundry.com/en/blog/ux-design/design-thinking-examples/ https://online.hbs.edu/blog/post/design-thinking-examples https://www.healing-power-of-art.org/positive-art-news-creativity-turns-scary-mri-scanner-for-kids-into-an-adventure/
1M	Applying Design Thinking to Sustainable Energy	http://innodigest.com/design-thinking-to-sustainable-energy/
1N	How can 'Design Thinking' help utilities prepare for a new energy future?	https://www.linkedin.com/pulse/how-can-design-thinking-help-utilities-prepare-new-energy-singh
2	Electric Vehicle Charging Infrastructure Planning and Rollout for Bengaluru City, Karnataka	a. indiasmartgrid.org > reports > BESCOCM EVCI Planning b. https://e-amrit.niti.gov.in/standards-and-specifications c. https://deltaelectronicsindia.com/

3	Choosing charging cable for Electric car	https://www.carplug.eu/which-charging-cable-for-electric-car#courant_AC
4	When to use ac and dc charging to charge an electric vehicle?	https://www.evplugincharge.com/blogs/when-to-use-ac-and-dc-charging-for-charge-electric-vehicle/blog-details
5	Types of charging stations	https://www.ev-resource.com/types-of-charging-and-charging-stations.html
6	Handbook of electric vehicle charging infrastructure implementation	www.niti.gov.in > sites > default
7	Setting up an EV Charging station	https://evduniya.com/ev-india/charging-stations/how-to-setup-an-ev-charging-station-in-india.html
8	Minimum requirements of public charging Infrastructure	https://electricvehicles.in/charging-infrastructure-guidelines-and-standards-for-electric-vehicles-released-by-indian-ministry-of-power/
9	Cost of Setting up Electric Charging Stations in India	https://e-vehicleinfo.com/charging-stations-in-india-cost-companies-franchise/
10	Cost of Setting up Electric	https://www.lendingkart.com/blog/cost-estimates-of-ev-public-charging-station/

	Charging Stations in India	
11	Government guidelines for Setting EV Charging Stations	powermin.gov.in › sites › default
12	Karnataka EV Policy	https://e-vehicleinfo.com/karnataka-ev-policy/
13	Vehicle to grid	a) https://youtu.be/wHNFYMPFUv4 b) https://www.youtube.com/watch?v=LFKKPy3LUVVM c) https://youtu.be/QCYcsk40FLs
14	Vehicle to Home	https://youtu.be/Hcw0f1V2BRQ
15	SUPERVISORY CONTROL AND DATA ACQUISITION (SCADA)	https://nptel.ac.in/courses/108106022
16	Difference between PLC and RTU	https://youtu.be/Ax1jTp2dl9M
17	Multifunction transducer	http://www.icdipl.net/product/multifunction-transducer/
18	Intelligent electronic device	https://www.techtarget.com/whatis/definition/intelligent-electronic-device https://electronicscoach.com/intelligent-electronic-devices.html https://www.igrid-td.com/smartguide/gridandsubstationautomation/ied-intelligent-electronic-device/
19	Smart Grid Handbook for Regulators and Policy Makers	indiasmartgrid.org › reports › Smart Grid Handbook

20	Smart Grid	https://archive.nptel.ac.in/courses/108/107/108107113/
20a	<u>The smart grid: enabling energy efficiency and demand response</u>	<u>Clark W. Gellings</u>
20b	Virtual tour on smart grid	https://www.youtube.com/watch?v=ubNGhL4iUAU
21	Smart grid of tomorrow	npti.gov.in › sites › default
22	Installation & testing of smart meters	https://www.networkedenergy.com/en/smart-meter-installation-how-to
23	Simulation of simple smart grid	https://www.youtube.com/watch?v=Uv0Jh534cok&t=544s
24	Introduction of IoT	a) https://www.geeksforgeeks.org/introduction-to-internet-of-things-iot-set-1/ b) https://infyspringboard.onwingspan.com/web/en/viewer/video/lex_auth_01281271072738508814673shared?collectionId=lex_auth_0130944265535569922151_shared&collectionType=Course
25	IoT environment for basic applications	Internet of Things (IoT) Set 2 - GeeksforGeeks
26	Introduction to NODE MCU	https://www.nodemcu.com/index_en.html
27	IoT-based Smart Energy Meter using NodeMCU ESP8266	a) https://iotdesignpro.com/projects/iot-based-smart-energy-meter-using-nodemcu-esp8266 b) https://iotdesignpro.com/projects/iot-based-smart-energy-meter
28	Automation system to	https://easyelectronicproject.com/esp32-projects/esp8266-mqtt-home-automation-system/

	control appliances from anywhere through the internet	
29	Raspberry pi	https://analyticsindiamag.com/raspberry-pie-important-iot/
30	IoT-based Smart Energy Meter using Raspberry pi	https://circuitdigest.com/microcontroller-projects/iot-based-raspberry-pi-smart-energy-meter
31	Applying IoT technologies in the Electric Power Industry	https://softengi.com/blog/iot-solutions-for-the-electric-power-industry/
32	IoT-Based Energy Management System	https://www.researchgate.net/publication/360034488_IoT_Based_Energy_Management_System
33 a	Benefits of Smart Energy Management using IoT	https://-of-iot-in-energy-management/ https://iot4beginners.com/application-of-f-things-energy-
33 b	HVDS	https://youtu.be/uQOfOWJsRKA https://youtu.be/R52DAQVwjeE
34	Demand-side management	https://www.mdpi.com/1996-1073/15/8/2863/html https://www.mepits.com/tutorial/447/electrical/demand-side-management-tutorial http://large.stanford.edu/courses/2010/ph240/malone1/
35	Demand-side management	https://archive.nptel.ac.in/courses/109/106/109106161/
36	Agriculture side Demand	a) https://beeindia.gov.in/content/agriculture-dsm-0kredl.karnataka.gov.in › storage › pdf-files b) http://agdsm.in/

	Side Management	
37	Municipal demand side management	https://beeindia.gov.in/content/municipal-dsm
38	Ongoing DSM projects in Karnataka	https://bescom.karnataka.gov.in/page/Departments+of+Corporate+Office/DSM/On+going+DSM+Projects/en
39	DSM measures by Distribution Companies	https://beeindia.gov.in/content/publications-0
40	Energy management and audit	https://beeindia.gov.in/sites/default/files/1Ch3.pdf
41	EESL (Energy efficiency services Limited) Mobile App	https://eeslindia.org/en/home/
42	Introduction to Data Centre	https://beeindia.gov.in/sites/default/files/datacenterbook.pdf
42	Substation equipment needed to power up data centre	https://electrical-engineering-portal.com/substation-data-center#medium-voltage-switchgear
42	<i>Cost of Data Center Outages</i>	https://www.cablinginstall.com/data-center/article/16465938/causes-and-costs-of-data-center-outages
42	Modular/compact ups used in Data centers	https://www.se.com/in/en/product-category/8000-uninterruptible-power-supply-ups/

43	How to measure power quality? What devices should you use and what to measure?	https://electrical-engineering-portal.com/how-to-measure-power-quality
44	Power quality meters	a. https://new.siemens.com/us/en/products/energy/low-voltage/digital-power-monitoring/power-quality-meters-accessories.html b. https://www.fluke.com/en-in/products/electrical-testing/power-quality
45	Understanding Importance of Power Quality in the Data Center	https://powerside.com/wp-content/uploads/2021/05/DCF-Special-Report-Power-Quality-in-the-Data-Center.pdf
46	Fail-safe bypass/isolation switches	https://digitalcontentcenter.compas.siemens-info.com/RUS_WP_Fail-safe-vs-Maintenance-Bypass.pdf
47	Power Usage Effectiveness	https://www.digitalrealty.com/data-center-power
48	Recommended practice for electrical preventative maintenance	https://www.munichre.com › renditions › original.PDF
49	Ways Data Centres Can Improve Energy Efficiency	https://www.facilitiesnet.com/datacenters/article/8-Ways-Data-Centers-Can-Improve-Energy-Efficiency--19375
50	Data centre energy management	http://www.cei.washington.edu/research/energy-systems/data-center-energy-management/

51	Best practices for energy management	https://statemigration.com/best-practices-for-energyefficient-data-center-design/
52	Energy-efficient guideline and best practices in energy management in Indian data centres	https://beeindia.gov.in > sites > default > files > data...
53	Data center case study 4	9AKK107991A1983_ABB-Whitepaper-DataCenter-Benefits-of-monitoring-and-diagnostic-solutions.pdf
54	Water consumption in data centers	https://www.watercalculator.org/footprint/data-centers-water-use/
55	Estimating a data center's carbon footprint	https://www.insight.com/content/dam/insight/en_US/pdfs/apc/apc-estimating-data-centers-carbon-footprint.pdf
56	Datacentres in Bangalore	https://www.datacentermap.com/india/bangalore/
57		https://www.seaenergy.in/post/bee-exam-practice-test-paper-1-1

CIE and SEE Assessment Methodologies

CIE Assessment	Assessment Mode	Duration In hours	Max Marks
Week 3	CIE 1- Written and practice test	4	30
Week 5	CIE 2- Written and practice test	4	30
Week 7	CIE 3- Written and practice test	4	30
Week 9	CIE 4- Written and practice test	4	30
Week 11	CIE 5- Written and practice test	4	30
	On line Course work (Minimum 10 hours online course with certification from (SWAYAM/NPTEL/Infosys Springboard)		40
	Profile building for Internship / Submission of Synopsys for project work		20
Portfolio evaluation (Based on industrial assignments and weekly developmental assessment) *			30
TOTAL CIE MARKS (A)			240
SEE 1 - Theory exam (QP from BTE) Conducted for 100 marks 3 hrs duration reduced to 60 marks		3	60
SEE 2 - Practical		3	100
TOTAL SEE MARKS (B)			160
TOTAL MARKS (A+B)			400

* The industrial assignment shall be based on peer-to-peer assessment for a total of 10 marks (on a scale of 1 to 10) and in the event of a group assignment the marks awarded will be the same for the entire group, the developmental assessment will be for a total of 20 marks and based on MCQ/case study/demonstration and such other assignment methods

Assessment framework for CIE (1 to 5)

Note: Theory to be conducted for 1 hour and practice for 3 hours, total duration of exam - 4 hours

Programme	Electrical & Electronics Engineering	Semester	V
Course	Power Engineering	Max Marks	30
Course Code	20EE52I	Duration	4 hours
Name of the course coordinator			

Note: Answer one full question from each section.

Qn.No	Question	CL L3/L4	CO	PO	Marks
Section-1 (Theory) - 10 marks					
1.a)	Classify EV charging infrastructure with neat sketch.	L3	1	1	5
b)	What type of connectors you recommend for a 4 wheeler for AC charging/DC charging	L3		1	5
2.a)	Which IEC standard defines different modes for EV charging and explain those charging modes with a neat sketch.	L3		1	10
Section-2 (Practical) - 20 marks					
3)a.	Identify components of a charging station and demonstrate its working.	L3	1	2	10
b.	Identify different EV charging connectors	L3		2	5
c.	Select the suitable charger for a given vehicle type power rating and voltage	L3		2	5

Note : Theory questions shall be aligned to practical questions

Assessment framework for SEE 1 (Theory)

Programme :	Electrical & Electronics Engineering	Max Marks :	100
Semester :	V	Duration :	3 Hrs
Course :	Power Engineering		
Course Code :	20EE52I		





Instruction to the Candidate: Answer one full question from each section.

Q.No	Question	CL	CO	Marks															
Section-1																			
1.a)	How will you apply design thinking process to install EV charging station in your institute?	L4	1	5															
b)	Differentiate between level 1, Level 2 and Level 3 charging. Select suitable charging levels for Two wheelers and Four wheeler vehicle. Select type connectors for only DC charging.	L3		10															
c)	What do you think are the main barrier holding the commercialization of high voltage high power wireless power transfer (WPT) for EV? Which IE standard covers wireless power transfer?	L3		5															
2.a)	Which charging protocol you suggest which provides DC charging standards for EV that ensures seamless communication between charging point and vehicle and justify your suggestion.	L4		5															
b)	Can you charge EV vehicle by wireless power transfer methods? Justify your answer with neat sketch.	L3		10															
c)	What type of converters you suggest to be included in a DC charging station? Justify your answer with neat block diagram.	L3		5															
Section-2																			
3.a)	<p>A family based in Delhi is planning to purchase an electric four-wheeler with a battery capacity of 45 kWh. It is evaluating whether an EV metered connection is economical, considering that the alternative is to use the existing Domestic electricity connection. The family's average monthly electricity consumption from April to September is about 380 units and its sanctioned load has headroom to meet an additional load of about 3 kW. What is the most economic option for the family?</p> <table border="1" style="margin-left: auto; margin-right: auto;"> <thead> <tr> <th colspan="5">Energy charges(₹/kWh) based on monthly consumption</th> </tr> <tr> <th>0-200 units</th> <th>201-400 units</th> <th>401-800 units</th> <th>801-1200 units</th> <th>>1200 units</th> </tr> </thead> <tbody> <tr> <td>3.00</td> <td>4.50</td> <td>6.50</td> <td>7.00</td> <td>8.00</td> </tr> </tbody> </table>	Energy charges(₹/kWh) based on monthly consumption					0-200 units	201-400 units	401-800 units	801-1200 units	>1200 units	3.00	4.50	6.50	7.00	8.00	L3	2	10
Energy charges(₹/kWh) based on monthly consumption																			
0-200 units	201-400 units	401-800 units	801-1200 units	>1200 units															
3.00	4.50	6.50	7.00	8.00															

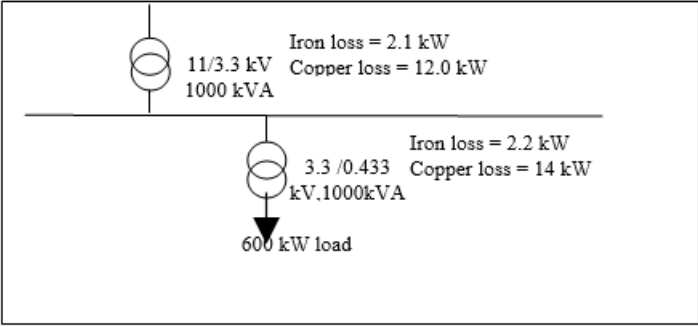
	A domestic household connection in Delhi attracts energy charges based on consumption slabs, as shown in the table above. Delhi's EV tariff has an energy charge of ` 4.50 per unit and no demand charge. For the family's requirement, the EV needs to be charged every five days, from 20% to 100% state of charge. The monthly electricity consumption from EV charging thus comes out to approximately 216 units																										
b)	Suggest any device is to detect the fault current EV charging station and how will you install such device in EV charging stations.	L3		10																							
4. a)	A CPO has identified a location for setting up a standalone charging facility and wants to install two 50 kW chargers, three 7 kW chargers, and a 9-unit stack battery charging system. After consulting the DISCOM, it is found that the nearby DT has available capacity to support an additional load of 48 kW, beyond which its capacity would need to be augmented. Moreover, the supply code stipulates 7 kW and 65 kW as the maximum sanctioned load limits for single-phase LT and three phase LT electricity connections respectively.			10																							
b)	What do think are the key challenges faced integrating EV charging infrastructure with the grid support your answer with sketches and graphs?	L3		10																							
Section- 3																											
5. a)	Compute AT & C (Aggregate Technical and Commercial) Losses for the following data:																										
	<table border="1"> <thead> <tr> <th>S. No.</th> <th>Description</th> <th>Annual Data</th> </tr> </thead> <tbody> <tr> <td>1</td> <td>Input Energy = (Import-Export), MU</td> <td>11</td> </tr> <tr> <td>2a</td> <td>Energy Billed (Metered), MU</td> <td>7</td> </tr> <tr> <td>2b</td> <td>Energy Billed (Un-Metered), MU</td> <td>1</td> </tr> <tr> <td>2c</td> <td>Total Energy Billed</td> <td>8</td> </tr> <tr> <td>3</td> <td>Amount Billed (Rs. lakhs)</td> <td>450</td> </tr> <tr> <td>4a</td> <td>Gross Amount Collected (Rs. lakhs)</td> <td>460</td> </tr> <tr> <td>4b</td> <td>Arrears Collected (Rs. lakhs)</td> <td>40</td> </tr> </tbody> </table>	S. No.	Description	Annual Data	1	Input Energy = (Import-Export), MU	11	2a	Energy Billed (Metered), MU	7	2b	Energy Billed (Un-Metered), MU	1	2c	Total Energy Billed	8	3	Amount Billed (Rs. lakhs)	450	4a	Gross Amount Collected (Rs. lakhs)	460	4b	Arrears Collected (Rs. lakhs)	40	L3	5
S. No.	Description	Annual Data																									
1	Input Energy = (Import-Export), MU	11																									
2a	Energy Billed (Metered), MU	7																									
2b	Energy Billed (Un-Metered), MU	1																									
2c	Total Energy Billed	8																									
3	Amount Billed (Rs. lakhs)	450																									
4a	Gross Amount Collected (Rs. lakhs)	460																									
4b	Arrears Collected (Rs. lakhs)	40																									
b)	Is Time of Day (TOD) Tariff is beneficial for Utility And consumers? Justify your Answer.	L3	3	7																							
c)	What is IED? Can it perform the role of protective relay? Justify your answer. Name any one communication protocol it supports.	L3		8																							
6. a)	Compare smart grid with conventional utility grid.	L3		5																							
b)	Case: The CESC, Mysore Smart grid pilot Project involves 21,824 consumers with a good mix of residential, Commercial, industrial and agricultural consumers including 512 irrigation pump sets covering over 14 feeders and 473 distribution transformers and accounting for input energy of 151.89 MU. Additional functionality like Agriculture DSM with community portal, consumer portal to support DSM/DR,	L4		10																							

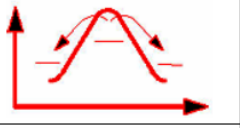
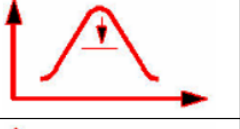
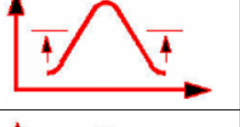
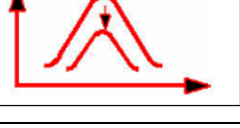
	<p>employee portal for knowledge sharing and benefit realization, KPI based MIS and data analytics for decision support are also proposed.</p> <p>19600 Single Phase meters, 548 three phase smart metrs, 453 DCUs, 318 DTMU, 5 FPIs and 130 HT modems installed. 16000 meters and 80 modems are communicating with Head End System. 500 RF pre-payment meters delivered. 494 installed and 300 of them commissioned. 200 RF Net meters delivered, 1 meter installed. 53 LT-CT meters installed.</p> <ol style="list-style-type: none"> 1. What do you understand from the term "Agriculture DSM ". 2. What would be the likely benefits and outcomes from this Smart grid pilot project . 			
c)	<p>Case study: MERC introduced reliability surcharge for withdrawal of load shedding. During 2006-07, in order avoid Load shedding in Pune City, the stranded/ surplus Captive Power Plant Capacity in and around Pune (about 90 MW) was used to mitigate the Load shedding. During the Load shedding hours, these Captive Plants (costly power) were put "ON" and load shedding in Pune city was avoided transforming Pune as the "Zero load Shedding" City. The charges for Captive Power (Costly power), used to mitigate the Load shedding, were being charged to all consumers in Pune city. The Domestic Consumers with consumption less than 300 Units/ month Were excluded from charging the Surcharge. All other Consumers in Pune City were levied Reliability Charge of Rs. 0.42 per Unit, which was in lieu of providing reliable supply to consumers (Zero Load shedding) What conclusions can you draw from the above case study</p>	L4		5
Section-4				
7.a)	<p>An energy manager or energy auditor is trying to establish the power factor of a 15 HP induction motor. The instrument to measure electric parameters displays the three numbers 5 kW and 2 kVAr and PF = 92.8%. Do you fully agree with the instrument display and its correctness?</p> <p>OR</p> <p>Energy auditor is invited by an old textile mill to identify the scope of electricity savings in the distribution system. After, a visit to the mill substation, the auditor observes the following voltage distribution arrangement. In your view, what best option he would like to suggest to the management for its detail investigation.</p> <p>(Note: The detail technical and financial implications at this stage are not to be considered. Only concept to be mentioned)</p>	L4	4	5

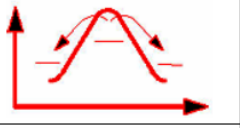
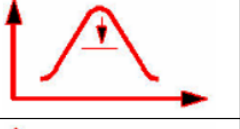
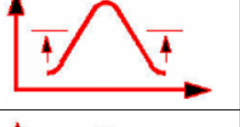
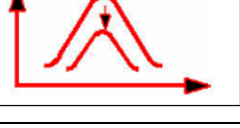
				
<p>b)</p>	<p>Suggest new method to ESCOMS to reduce distribution losses in your area. Perform cost benefit analysis for the project.</p>	<p>L3</p>		<p>10</p>
<p>c)</p>	<p>What is motor load survey? Suggest Energy Conservation Measures for the following 35 to 50% Load variation > 50- 60% Loading</p>	<p>L3</p>		<p>5</p>
<p>8.a)</p>	<p>A 15 kW rated motor burns out. The financial manager of the firm wants to rewind the motor for Rs.3000 to save money. The Energy Manager wants to buy a new premium motor for Rs.20,000/- after selling motor for Rs. 5,000. He claims that he can save much more money in the next five years than the cost difference of the above two options. Other data is as under:</p> <p>Operating hours/year = 8000</p> <p>Rewound motor efficiency = 89%</p> <p>New premium motor efficiency = 93%</p> <p>Motor loading = 75%</p> <p>Power cost = Rs.4/kWh</p> <p>(i) How much money does the energy manager actually save over 5 years and what is the simple payback period?</p>	<p>L3</p>		<p>10</p>

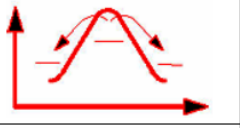
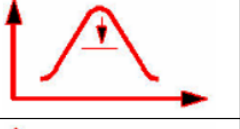
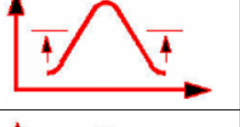
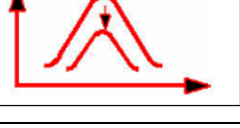
	(ii) The financial manager claims the financial risk is still too high because operating hours may go down drastically in the next years. How many operating hours/year are required to recover the cost difference within 5 years.																							
b)	An energy auditor works out the percentage loading of a particular induction motor as a ratio of current drawn to the rated current of the motor. a) Do you agree with the above methodology adopted by the consultant? Justify your answer with reasons. b) In your opinion what is the right approach for working out the motor loading?	L3		5																				
c)	Match the following load-shape objectives of any Demand Side Management (DSM) programme of a utility. <table border="1" style="width: 100%; border-collapse: collapse;"> <tr> <td style="width: 5%; text-align: center;">i</td> <td style="width: 25%;">Peak Clipping</td> <td style="width: 5%; text-align: center;">a</td> <td style="width: 65%;"></td> </tr> <tr> <td style="text-align: center;">ii</td> <td>Valley filling</td> <td style="text-align: center;">b</td> <td></td> </tr> <tr> <td style="text-align: center;">iii</td> <td>Load shifting</td> <td style="text-align: center;">c</td> <td></td> </tr> <tr> <td style="text-align: center;">iv</td> <td>Conservation</td> <td style="text-align: center;">d</td> <td></td> </tr> <tr> <td style="text-align: center;">v</td> <td>Load building</td> <td style="text-align: center;">e</td> <td></td> </tr> </table>	i	Peak Clipping	a		ii	Valley filling	b		iii	Load shifting	c		iv	Conservation	d		v	Load building	e		L3		5
i	Peak Clipping	a																						
ii	Valley filling	b																						
iii	Load shifting	c																						
iv	Conservation	d																						
v	Load building	e																						
Section-5																								
9.a)	Case : The company is an Indian telecom giant with an exclusive Datacentre catering to their internal needs. The organization conducted an energy study to look into opportunity-related cost reduction through	L4		10																				

	<p>Better energy management. The measured system power factor was 0.88 lagging for the average load of 1030 kW. The harmonic levels in the system were also measured with a power quality analyser. Answer the following questions.</p> <ol style="list-style-type: none"> 1. How will you improve the factor to 0.97? 2. What are causes for poor power factor? 3. Why harmonics are generated in Datacentre. 4. How will you solve harmonics problem. 5. What are likely benefits of improving power factor and minimising harmonics? 			
b)	What do you think are the key factors affects the carbon footprint of a datacentre, justify the answer with facts and figures.	L3		10
10.a)	<p>Case:</p> <ul style="list-style-type: none"> • The organization is a well-known software development company with international clientele. The • Organization maintains a Datacentre which caters to the needs of various clients abroad. The company initiated various programmes for energy management and also conducted Power Quality and Energy audit. • During the assessment of the UPS, the loading on the UPS system was found to be changing constantly. • The change in loading pattern was due to • Flexible operating hours of developers resulting in randomness of load • A number of software development projects being worked upon • For a maximum load of 200 kVA, four modules of 200 kVA UPS were installed in a 4 x 200 KVA configuration as shown in figure 2.27. Thus, even if the load equals 200 kVA, each UPS would be loaded to a maximum of 25% only. In reality, the load was never 200 kVA but lower, varying from a minimum of 100 kVA to a maximum of 144 kVA at different times of a day, thus imposing loads of differing percentages on the UPS systems. The loading pattern observed for 	L4	5	10

the period of two days is shown in figure

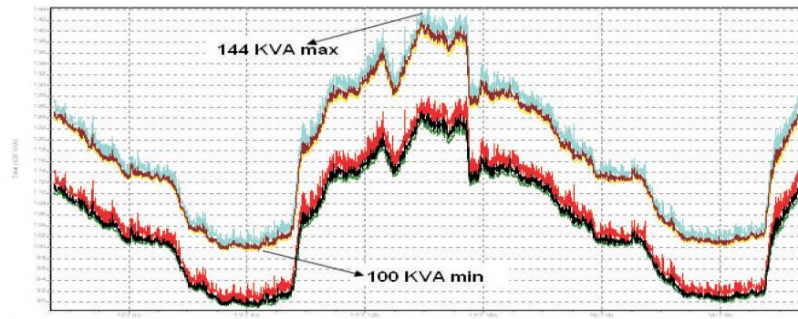

%Loading	Efficiency
10%	80.00%
15%	84.00%
20%	87.00%
25%	89.16%
30%	91.00%
40%	91.95%
50%	92.80%
60%	93.00%
70%	93.40%
80%	93.46%
90%	93.15%
100%	93.00%

EFFICIENCY DATA OF 200 KVA UPS SYSTEM

Answer the following questions.

1. What is the UPS efficiency when the load varies from 100KVA to 144 KVA?
2. How will you improve the UPS efficiency?

	3. Suppose the efficiency of the UPS system was improved by 6.7%. What is likely reduction of demand consumption? 4. What is the financial implication of your solution?			
b)	Suggest the substation equipment needed to power up the data centre, justify your answer with neat block diagram.	L3		10

Scheme of Evaluation for SEE 2

Sl. No	Description	Marks
1	Identify charging level , plugs , sockets and connector and associated charging protocols as per given requirements	10
2	Install, Commissioning and testing of EV station	30
3	Simulation exercise on EV/SCADA/smart grid/IOT OR Automate given system using IOT OR Install and Test smart energy meter	30
4	Measure and analyse power quality parameters using a power analyser for the any given load. Suggest remedial measures to mitigate power quality issues.	20
5	Energy audit report	05
6	Demonstrate the use of the energy audit instruments.	05
Total		100

Equipment/Software list with Specification for a batch of 20 students

Sl. No.	Description of the equipment/ Hardware/ Software	Specification	Total Quantity Required (A)
1	Charging Station	Bharat AC-001, 3.3 kW Output Power	1
2	Charging Station	Bharat DC-001, 15 kW Output Power	1
3	Charging Station	Type 2 AC , 22 kW Output Power	1
4	Arduino Board		10
5	Raspberry PI		5
6	Smart Energy Meter	1ph and 3ph, LCD with pulse output	2
7	Digital Lux Meter		2
8	Infrared Thermometer		2
9	TDS meter		2
10	Power Quality analyser		2
11	SCADA lab kit	PUSPAC-RTU with field simulation bench IEC 60870-5-104 compliant Master/RTU simulator IEC 60870-5-101 - IEC 60870-5-104 protocol converter User friendly web based GUI Historical database management Flexible reporting system and trending Customized tag configuration Alarm/Event handling Can connect to IEC 60870-5-104 compliant RTU Can connect to IEC 60870-5-101 compliant RTU using "SMART ProGate"	1



Government of Karnataka
DEPARTMENT OF COLLEGIATE AND TECHNICAL EDUCATION

Program	Electrical & Electronics Engineering	Semester	5
Course Code	20EE53I	Type of Course L: T:P	Integrated 104:52:312
Specialization	Renewable Energy	Credits	24
CIE Marks	240	SEE Marks	160

Introduction:

Renewable energy provides reliable power supplies and fuel diversification, which enhance energy security, lower the risk of fuel spills, and reduce the need for imported fuels. Renewable energy also helps conserve the nation's natural resources. Renewable energy is a term for clean, sustainable energy that's derived from naturally regenerating sources. Using a combination of these natural sources and intelligent technology, we can generate enough heat and electricity for all our homes, businesses, and production needs. This specialisation course is taught in Boot camp mode. Boot camp are 12 weeks, of intense learning sessions designed to prepare the student for practical world – ready for either industry or becoming an entrepreneur. Students will be assisted through the course, with development-based assessments to enable progressive learning.

Pre-requisite

Before the start of this specialisation course, the students shall have prerequisite knowledge gained in the first two years on the following subjects:

1st year – Engineering Mathematics, computer Aided Engineering Graphics, Fundamentals of Electrical and Electronics Engineering and Basics of Electrical power system, Communication Skills, Statistics & Analysis, Basic IT Skills, Project Management skills and Residential wiring.

2nd year- Transformers and Alternators, Transmission and Distribution, Switchgear and Protection, Analog and Digital Electronics, Electrical motors, Power Electronics, Fundamentals of Automation Technology ,and Computer-Aided Electrical Drawing.

In the third year of study, student shall be applying previous years learning along with specialised field of study into projects and real-world applications.

Course Cohort Owner

A Course Cohort Owner is a faculty from the core discipline, who is fully responsible for one specialized field of study and the cohort of students who have chosen to study that specialised field of study.

Guidelines for Cohort Owner

1. Each Specialized field of study is restricted to a Cohort of 20 students which could include students from other relevant programs.

2. One faculty from the Core Discipline shall be the Cohort Owner, who for teaching and learning in allied disciplines can work with faculty from other disciplines or industry experts.
3. The course shall be delivered in boot camp mode spanning over 12 weeks of study, weekly developmental assessments and culminating in a mini capstone.
4. The industry session shall be addressed by industry subject experts (in contact mode/online / recorded video mode) in the discipline only.
5. The cohort owner shall be responsible to identify experts from the relevant field and organize industry sessions as per schedule.
6. Cohort owner shall plan and accompany the cohort for any industrial visits.
7. Cohort owner shall maintain and document industrial assignments, weekly assessments, practices and mini-project.
8. The cohort owner shall coordinate with faculties across programs needed for their course to ensure seamless delivery as per time table
9. The cohort owner along with classroom sessions can augment or use supplementally teaching and learning opportunities including good quality online courses available on platforms like Karnataka LMS, Infosys Springboard, NPTEL, Unacademy, SWAYAM, etc.

Course outcome:

On successful completion of the course, the students will be able to:

C01	Design and install a solar PV system.
C02	Test, Commission, maintain, and monitor electrical and weather parameters for a solar PV system.
C03	Install and test solar EV charging station.
C04	Design and install small wind and biogas power plants.
C05	Perform feasibility study to suggest appropriate sustainable energy and energy storage solutions for an educational institute/commercial building/industry.

Detailed Course Plan

Week	C O	P O	Days	1 st session (9 am to 1 pm)	L	T	P	2 ND session (1.30 pm to 4.30 pm)	L	T	P
1	5	1,5	1	<p>Introduction to Renewable energy Introduction to sustainability: -Meaning of sustainability -Components of sustainability Ref:1</p> <p>6Rs of sustainability -Rethink, Refuse, Reduce, Reuse, Recycle, Repair -Examples</p> <p>-Seventeen Sustainable Development Goals? Ref:2 -Video demonstration 6Rs of sustainability</p>	1		3	<p>Decarbonization : -How Does Decarbonisation Work? -Why is Decarbonisation Important? -How do we Decarbonise?</p> <p>NetZero: -Meaning of NetZero, -Difference between NetZero and zero. Video demonstration of decarbonisation</p> <p>Sustainability Carbon footprint calculator: Ref:3 -Calculate your family's carbon footprint and analyze</p>	1		2
	5	1,5	2	<ul style="list-style-type: none"> • Sustainable Manufacturing for India's Low-Carbon Transition <p>Ref:4</p> <ul style="list-style-type: none"> • Power Positive <p>Ref:5</p> <ul style="list-style-type: none"> • Video demonstration of Sustainable Manufacturing • Video demonstration on Power Positive <p>Agrovoltaics</p> <ul style="list-style-type: none"> • Advantages and disadvantages of agrovoltaic energy • Applications of agrovoltaics • Benefits of agrovoltaics <p>Ref:8 Video demonstration agrovoltaic</p>	1		3	<p>Global Energy scenario Indian Energy Scenario, Energy Policy</p> <ul style="list-style-type: none"> • Prepare table: (All India): Installed capacity for thermal, hydro, nuclear, and Renewable energy sources. • Prepare table: (Karnataka): Installed capacity for thermal, hydro, nuclear, and Renewable. Ref:6a • Electricity Price & Availability <p>Ref: 6b</p> <p>Renewable Energy Sources:</p>	1		2

							<ul style="list-style-type: none"> • -Hydro • -Solar • -Wind • -Biomass • -Hydrogen • -Geothermal • -Ocean <p>The basic principle of working, its benefits and disadvantages.</p> <ul style="list-style-type: none"> • Video Demonstration of Renewable Energy technologies. 			
	1,5	3	Design thinking What is design thinking? 5 steps of Design Thinking. Ref.7a.b Why is design thinking so important? Ref.7c	1		3	Examples of design thinking Ref.7d,e,f			3
	1,5	4	Applying Design Thinking to Sustainable Energy Ref.7.i	1		3	How can 'Design Thinking' help utilities prepare for a new energy future? Ref.7.g Reinventing solar energy supply for rural Africa Ref.7.h.	1		2
		5	Developmental Assessment	-	-		Assessment Review and corrective action			3
		6	Industry Class + Assignment	2		3				

2	1	1,5	1	Peer discussion on Industrial assignment.	4		Introduction to solar energy: <ul style="list-style-type: none"> • Solar Irradiance Concepts: • DNI(Direct normal irradiance). • Global horizontal radiance (GHI), • Diffuses horizontal radiation (DHI), • Relation between GHI, DNI and DHI. • Global Tilted Irradiance (GTI). Practice <ul style="list-style-type: none"> • Compass (Direction of solar panel) • Calculation of tilt angle. • Lumen meter or Lux meter • Solar radiation measurement 	1		2
	1	1,5	2	Understand Terminology used in the Solar Industry: <ul style="list-style-type: none"> • Photovoltaic (PV) cell • Module • Array • Balance of system, • Efficiency of solar panel • Electrical (or electric or utility) grid • Ground-mounted Solar • Interconnection agreement • Mounting hardware • Net metering • Operations and maintenance • Solar batteries (or storage) • Solar canopies • Solar carports • Solar dealer 	2	2	Solar PV Systems <ul style="list-style-type: none"> • Identify and understand the working, advantages, and efficiency of different types of Solar PV Systems: -by configuration- Stand-alone, grid-tied, grid interactive, and hybrid -by deployment- Ground Mount, rooftop, Agro PV, Floating PV and BIPV (Building-integrated photovoltaics). Ref:10 -by appearance -Monocrystalline, polycrystalline, thin-film (amorphous), Ref:12 Bifacial modules -Half-cut solar cell technology: working and advantages	2		1

			<ul style="list-style-type: none"> • Solar design • Solar installer • Solar panel cleaning • Solar power plant • Thin-film solar • Solar Tracker <p>Ref:9 -Demonstrate the Manufacturing of solar cells. -Identify the different components of a Solar PV system and understand its basic operation</p>				- Current manufacturers of half-cut cells. Ref:11			
1	2,4,5	3	<p>Solar Panel</p> <ul style="list-style-type: none"> • Standard size and weight of the solar panel • Demonstrate different types of solar panels. • Specification of solar panel <p>Ref:13 Terms used in solar panel</p> <ul style="list-style-type: none"> • Open Circuit Voltage (Voc). • Short Circuit Current (Isc), • Maximum Power Point (Pmax), • Maximum Power Point Current (Impp), • Nominal Voltage. • Module efficiency • Maximum operating voltage • Maximum operating current • Maximum system Voltage • Maximum series fuse rating <p>-Interpretation of datasheet of PV module. Ref:14</p>	1	3	<p>Solar Panel sizing Sizing of a solar panel for an application Ref:15 -Test a given solar panel Ref:15c</p>				3
1	1,2,5	4	<p>Solar Batteries Types of solar batteries: -Advantages, disadvantages, and applications.</p> <ul style="list-style-type: none"> • Lead-acid batteries • Nickel cadmium batteries 	2	2	<p>Solar Batteries</p> <ul style="list-style-type: none"> • Battery Sizing Calculation: Ref:19 • Battery sizing guidelines Ref:20 				3

			<ul style="list-style-type: none"> • Flow batteries • Lithium-ion batteries <p>C- and E- rates:</p> <p>Ref:16</p> <p>Technical specification of batteries:</p> <ul style="list-style-type: none"> • Nominal Voltage (V) • Cut-off Voltage • Capacity or Nominal Capacity (Ah for a specific C-rate) • Energy or Nominal Energy (Wh (for a specific C-rate)) • Cycle Life (a number for a specific DOD) • Specific Energy (Wh/kg) • Specific Power (W/kg) • Energy Density (Wh/L) • Power Density (W/L) • Maximum Continuous Discharge Current • Maximum 30-sec Discharge Pulse Current • Charge Voltage • Float Voltage • Charge Current • Internal Resistance • Battery Condition: • State of Charge (SOC)(%) • Depth of Discharge (DOD) (%) • Terminal Voltage (V) • Open-circuit voltage (V) • Internal Resistance <p>Ref:17</p> <p>Select a suitable battery for a given application:</p> <p>Ref:18</p>			<ul style="list-style-type: none"> • Test the condition of the given battery 			
1		5	Developmental Assessment	-	-	Assessment Review and corrective action			3

			6	Industry Class + Assignment	2		3				
Week	C O	P O	Days	1 st session (9 am to 1 pm)	L	T	P	2 ND session (1.30 pm to 4.30 pm)	L	T	P
3	1	2,5	1	Peer discussion on Industrial assignment.			4	Solar panel in simulation <ul style="list-style-type: none"> How to use solar panels in simulation Ref:21 <ul style="list-style-type: none"> Simulation of Solar power generation for home using any software Ref:22			3
	1	2,4,5	2	Charge controllers: <ul style="list-style-type: none"> Types of charge controllers: PWM charge controller and MPPT Sizing of PWM and MPPT charge controller Efficiency of PWM and MPPT charge controller Specifications of PWM and MPPT charge controller. Ref:23	2		2	Charge Controllers <ul style="list-style-type: none"> Identification and testing of Charge controllers. Ref:23 Connect the charge controller (12V, 10A) with a Solar battery (12V, 100Ah), Solar panel (75,W) and DC load and test. Power Optimizer Ref:24 <ul style="list-style-type: none"> Demonstrate Power Optimizer installation and operation Specification 			3
	1	2,5	3	Connectors used in Solar module -MC4 connector: Ref:25 <ul style="list-style-type: none"> Wiring MC4 Equipped Modules in Series. Wiring MC4 Equipped Modules in Parallel. -MC4 Connector Specifications: Ref:26 -Solar branch connectors Ref:27	1		3	Wires and Cables Types of DC wire used in solar panels <ul style="list-style-type: none"> PV wire USE-2 Sizing of DC cable Ref:28 <ul style="list-style-type: none"> Cable size between MPPT Controller and battery. 	1		2

							<ul style="list-style-type: none"> • Selection of the current carrying capacity of PV string cables. • Selection of the current carrying capacity of PV array cables. • Determining Cable Sizes in an Off-grid PV. 			
1	1,2,4,5	4	<p>Solar Inverters Types of solar inverters</p> <ul style="list-style-type: none"> • Centralized inverters • String inverters • Micro inverters • Inverter Architecture Choice <p>Ref:29</p> <p>-Specification of different types of Inverters -Demonstration of working of different types of Inverters</p> <p>Grid-Tied Solar String Inverters -Specifications</p> <p>Sizing of solar inverter</p> <ul style="list-style-type: none"> • Size a solar inverter for a given application <p>Ref:29</p> <ul style="list-style-type: none"> • Selection of inverter for a given solar application Ref:29 • Solar PCU • Specification of solar PCU 1kW/24V,1kW/48V,2kW/48V,3kW/48V <p>Ref:29</p>	2		2	<p>Mounting of Solar Panels</p> <ul style="list-style-type: none"> • Understand the different types, sizes, and specifications of foundations/ footings • Identify the need of mounting structures • Different types of mounting systems • Advantages and disadvantages of the different mount structure. <p>Ref:30</p> <p>Selection of right footing/foundation</p> <ul style="list-style-type: none"> • Select the right footing/foundation as per site location including suitability of roof condition or suitability of soil • Practice on mounting structures 	1		2
		5	CIE 1- Written and practice test	-	-	-	Assessment Review and corrective action			3
		6	Industry Class + Assignment	2		3				

Week	C O	P O	Days	1 st session (9am to 1 pm)	L	T	P	2 ND session (1.30pm to 4.30pm)	L	T	P
4	1	2,5	1	Peer discussion on Industrial assignment.			4	Design of off-grid rooftop PV System for a residence/commercial building <ul style="list-style-type: none"> Calculate monthly load and the energy consumption of your home from the electricity bill. Calculate the requirement of total units/day for your home. Estimate the size of the PV system. Ref:31 			3
		3,5	2	Design of off-grid rooftop PV System for a residence/commercial building Perform a site survey at rooftop area and prepare feasibility report including <ul style="list-style-type: none"> Inspection of field, Selection of site, Shadow analysis. Types of roofs, Weather monitoring. Solar path finder and sun path diagram. Wind Load conditions on Solar PV Panels like Wind Speed, Height of Panel above roof and Relative Location of Panels on roof. Create a rough layout of the rooms showing existing Grid meter line, MCB, nearest shaded & dry place for a solar PCU and place for panels. Prepare a layout of roof showing open areas and occupied areas and mark obstructions that can cause shadows. Take site photographs. Mark locations for components of solar PV electrical system on site. 	1		3	Selection of suitable PV system (standalone DC system/ standalone AC system/Grid tied PV system/Hybrid system) based on Load requirements – <ul style="list-style-type: none"> AC/DC Budget Existing form of supply System design : <ul style="list-style-type: none"> Module sizing and selection Battery sizing- Size the batteries and system voltage for the estimated PV system according to the required backup Size the charge controller for estimated battery system Select inverter, cable and conduit to match PV array; Sizing of inverters needed; 	1		2

			<p>Data to be collected during site survey :</p> <ul style="list-style-type: none"> Existing load and existing form of power supply. Location for placement of panel, battery, charge controller or PCU. Wire length from panel to battery and battery to load. Picture of site. Lay out of rooms, room type and floors. Available shadow free area. <p>Measuring instruments required for site survey :</p> <ul style="list-style-type: none"> Digital multimeter Compass AC/DC clamp meter Digital Luxmeter Power Guard meter 			<ul style="list-style-type: none"> Size and select the cable and conduit. Select suitable Module mounting structure for the above PV system Select suitable protective devices. Select the other miscellaneous system components <p>(Apply design thinking process)</p>			
1	3,5	3	<p>Design of off-grid rooftop PV System for a residence continued...</p> <ul style="list-style-type: none"> Prepare bill of material for above solar PV system and estimate the cost of installation. Calculate Payback period Calculate Carbon footprint <p>Introduction to solar PV design software</p> <ul style="list-style-type: none"> Design a PV system for the above residential/commercial building using any PV design software. 		4	<p>Design 100 KW solar PV system and estimate cost of installation and prepare a quotation, manually /PV design software.</p> <ul style="list-style-type: none"> Calculate Payback period Calculate Carbon footprint <p>Ref:32</p> <p>(Apply design thinking process)</p>			3
1	4,5	4	<p>Design and implement solar pumping system</p> <p>Ref:42a</p>	1	3	<p>Design and implement solar Street Light system</p> <p>Ref:39</p>	1		2

Week	C O	P O	Days	1 st session (9am to 1 pm)	L	T	P	(Apply design thinking process)			
								2 ND session (1.30pm to 4.30pm)	L	T	P
				Design a PV system to operate a flour mill. Ref:42b							
	1		5	Developmental Assessment	-	-		Assessment Review and corrective action			3
			6	Industry Class + Assignment	2		3				
5	2	1,5	1	Peer discussion on Industrial assignment.			4	Simulate PV MPPT Ref:33	3		
	2	4,5	2	Simulate 3MW grid connected by PV system Ref:34			4	Perform various measurements and tests pertaining to PV Modules and their installation as per IEC standards. <ul style="list-style-type: none"> Performance standards IEC 62125/61646 (Diagnostic, Electrical, Performance, Thermal, Irradiance, Environmental, Mechanical) IEC 61215 Safety Standards IEC 61730-1,2 (Electrical Hazards, Mechanical Hazards, Thermal Hazards, Fire Hazards) 	1		2
	2	4,5	3	Preparation for Installation Measuring instrument required at the site: <ul style="list-style-type: none"> Digital multimeter AC/DC clamp meter Hydrometer Tools used for installation <ul style="list-style-type: none"> Wire strippers Wire clippers Wire pliers Screw drivers Spanners Socket wrench 	1		3	Installing of PV components: <ul style="list-style-type: none"> Correct connection of batteries. Ventilation for batteries Connecting charge controller to battery ,panel and DC loads Connect solar power conditioning unit to battery bank Connect solar PCU to solar panel 			3

			<ul style="list-style-type: none"> • Tester • Hammer • Drilling machine and drill bit • Hacksaw blade <p>Safety precautions:</p> <p>Potential risks :</p> <ul style="list-style-type: none"> • DC side wiring • AC side wiring • Battery • Personal safety <p>Installation of Solar panel</p> <ul style="list-style-type: none"> • Steps for orienting of panels <p>Constructing the mounting structure</p> <ul style="list-style-type: none"> • Identifying the footing • Types of footing • Construction of mounting <p>Panel wiring :</p> <ul style="list-style-type: none"> • Difference between AC and DC wiring • Earthing of panels • Blocking and bypass diodes 			<ul style="list-style-type: none"> • Connect solar PCU to AC loads 			
2	4,5	4	<p>Installation and commissioning of Solar PV plant</p> <p>Wire the AC mains connection to the Solar PCU (Do not switch 'ON').</p> <ul style="list-style-type: none"> • Prepare a Checklist for finding out errors during above installation. • Check as per the checklist and prepare a clearance certificate before commissioning. • Perform Procedural first switch ON, observe No load test results and record. 		4	<p>Testing of PV Modules</p> <ul style="list-style-type: none"> • Carry out visual inspection of PV modules. • Measure Insulation resistance and Wet Leakage Current of PV Modules. <p>Ref:35</p> <ul style="list-style-type: none"> • Verify system grounding and measure insulation resistance. 			3

				<p>Perform 'ON Load' test, progressively add load till full load and record observation. Perform Overload test and record observation</p> <ul style="list-style-type: none"> • Prepare a First inspection report on the solar plant installation. • Prepare a list of Do's and Don'ts in the installation • Prepare a report on Customer orientation • Prepare a report on Visible and audio annunciators, alarms or alerts in a solar PCU. • Perform shutting down procedure of the above solar plant <p>Prepare a report on Customer orientation</p> <ul style="list-style-type: none"> • Prepare a report on visible and audio annunciators, alarms or alerts in a solar PCU. <p>Perform shutting down procedure of the above solar plant.</p>				<ul style="list-style-type: none"> • Perform Bypass Diode test - Pmax at STC and Pmax at low irradiance. • -check continuity of the system and verify polarity. • Measure Ground Continuity, Impulse Voltage, Reverse current and partial Discharge. • Practice to undertake precautions against Module breakage. • Demonstrate hot-spot on modules through audio visual aids. <p>Ref:36</p> <ul style="list-style-type: none"> • Measure DC voltages and currents for each string and array for proper operation of the system. • Verify inverter operation including anti-islanding performance and measure AC system values. 			
	2		5	CIE 2- Written and practice test	-	-	-	Assessment Review and corrective action			3
			6	Industry Class + Assignment	2		3				
Week	CO	PO	Days	1st session (9am to 1 pm)	L	T	P	2ND session (1.30pm to 4.30pm)	L	T	P
6	2	4,5	1	Peer discussion on Industrial assignment.		4		Maintain Solar Photovoltaic System <ul style="list-style-type: none"> • SOP (Standard Operation Procedures) of PV system. • Types of Maintenance 			3

							(Preventive/Corrective/Condition Based). <ul style="list-style-type: none"> Electrical maintenance /Solar Panel maintenance/ Battery maintenance/ Charge Controller Maintenance. Maintenance record 			
2	4,5	2	Maintain Solar Photovoltaic System Continued. <ul style="list-style-type: none"> Demonstrate Standard Operating Procedures of PV system. Demonstration of Solar Panel Maintenance: - Cleaning, Precautions While Cleaning DC Array Inspection Ref:37			4	Maintain Solar Photovoltaic System Continued. Demonstrate Electrical Maintenance of Inverters/Cables/Junction Boxes, Fault Indications of Inverters/PCU.			3
2	2,3	3	Maintain Solar Photovoltaic System Continued. <ul style="list-style-type: none"> Demonstration of Battery Maintenance- Checking of Electrolyte Level, Specific Gravity Using Hydrometer, Physical Damage, Terminal Voltage, Cleaning of Battery Terminals. 			4	Maintain Solar Photovoltaic System <ul style="list-style-type: none"> Inspection of Mounting Structure of Solar modules Procedure for replacement of defective Fixtures.			3
2	4,5	4	Case Studies on solar PV plants Case study on 1MW PV solar system Ref:38 Case study of 2GW solar power plant at Pavagada solar park Ref:40 Power Evacuation Scheme -Allocation to ESCOMS from solar park Ref:41			4	Solar Policies <ul style="list-style-type: none"> Central MNRE Solar policies (National Solar Mission, target 2030) State Solar and rooftop Policies, Solar Financing Economic Analysis of a Photovoltaic System: Energy economics basic concepts, unit cost of power generation from solar PV 	3		

								<ul style="list-style-type: none"> Payback period, LCC(life cycle costing) and benefit cost analysis. 			
	2		5	Developmental Assessment	-	-		Assessment Review and corrective action			3
			6	Industry Class + Assignment	2		3				
7	2	1,5	1	Peer discussion on Industrial assignment.		4		Introduction to SCADA: <ul style="list-style-type: none"> What is SCADA? SCADA SYSTEMS Evolution of SCADA Objective of SCADA. Benefits of SCADA Functions of SCADA: SCADA APPLCIATIONS Real-Time Monitoring and Control using SCADA Ref:43	2		1
	2	1,5	2	SCADA HARDWARE: <ul style="list-style-type: none"> SCADA Hardware Functions, Remote Terminal Units (RTU): RTU Hardware: A typical single board RTU. Hardware functionality in an RTU, RTU Software functions Basic operation: RTU Standards. Difference between PLC and RTU Features of SCADA Ref:43 <ul style="list-style-type: none"> Intelligent Electronic Devices (IEDs) 	2		2	SOFTWARE AND PROTOCOLS. <ul style="list-style-type: none"> ISO MODEL, DNP3 Protocol: Important Features of DNP3. IEC60870 PROTOCOL The two widely used protocols for SCADA Applications : <ul style="list-style-type: none"> HDLC (High Level Data Link Control) MODBUS The widely used open software for SCADA systems : <ul style="list-style-type: none"> Citect and Wonder ware. Ref:43	2		1
	2	4,5	3	Solar energy SCADA system <ul style="list-style-type: none"> Monitor inverter data 			4	Solar energy SCADA system Weather monitoring station Monitor radiation			3

				<ul style="list-style-type: none"> Monitor power generation plant, sub plant and string level Ref:44				<ul style="list-style-type: none"> Ambient temperature Humidity Ref:44			
	4,5	4		Solar energy SCADA system <ul style="list-style-type: none"> HT panel Incomer Relay data, Outgoing relay data, Incomer MFM's and Annunciator alarms and trip status. 			4	FIELD VISIT			3
	2		5	CIE 3- Written and practice test	-	-	-	Assessment Review and corrective action			3
			6	Industry Class + Assignment	2		3				
8	3	1,5	1	Peer discussion on Industrial assignment.		4		Necessity of Renewable Sources of Electricity to charge Electric Vehicles? Ref:49 Key Terminologies used in the EV Ecosystem: <ul style="list-style-type: none"> Electric Vehicle (EV) Battery Electric Vehicle (BEV) Hybrid Electric Vehicle (HEV) Plug-in Hybrid Electric Vehicle (PHEV) Charging Station/ Electric vehicle Charging Station (EVCS) Charging Point/ Electric Vehicle Supply Equipment (EVSE) Charging Pool, Connector Charge Point Operator (CPO). -Types of Electric vehicle, types of Engines -Stakeholders in EV Ecosystem Ref:50	2		1

3	1,4,5	2	<p>Charging technologies for Electric Vehicles:</p> <ul style="list-style-type: none"> • Classification of EV charging technologies • EV charging infrastructure classification <p>Conductive (Plug-in/Wired) charging:</p> <ul style="list-style-type: none"> • Modes of Charging {IEC 61851 standard} • Charging levels as per IEC 62196, IEC 61851 and SAE J1772 • Comparison between charging levels • Demonstrate (Video/physical) different EV charging technologies • Demonstrate (Video/physical) different modes of charging <p>Ref:50</p> <p>-Necessity of Power Converters for Charging Electric Cars from PV and wind? Ref:51</p>	2	2	<p>Technical Details of EV charger:</p> <ul style="list-style-type: none"> • Electric Vehicle battery charger components. • Block diagram of on-board EV charger, • Demonstrate (Video/physical) of EV charger components • Identify different EV charger components <p>Ref:50</p> <ul style="list-style-type: none"> • Charging: Level 1, Level 2 and Level 3 charging <p>Level 3 charging:</p> <ul style="list-style-type: none"> • Block diagram of DC charging station. • Communication and power flow between EV and EVSE: • DC charging station AC/DC converter and control • DC charging station DC/DC converter and control <p>Ref:50</p>	1	2
3	1,4,5	3	<p>-Charging speed</p> <p>-Connector Types</p> <ul style="list-style-type: none"> • Type 1/Yazaki (SAE J1772, IEC 62196-1) • Type 2 (IEC 62196-2) • Combined Charging System (CCS 1) • CHAdeMO • Combined Charging System (CCS 2) • GB/T DC Charger • Tesla Supercharger • Selection of charger for given vehicle type, power rating and voltage <p>Ref 52</p>	2	2	<p>Solar charging stations for electric vehicles (EV's)</p> <ul style="list-style-type: none"> • On-Grid solar charging stations • Off-Grid Solar charging station • Components needed for a solar charging station Ref:53 <p>How Many Solar Panels Does It Take to Charge an Electric Car? Ref:54</p>	2	1

				<ul style="list-style-type: none"> Identify different EV charging connectors. The Indian standards of charging connectors derived from the international standards <ul style="list-style-type: none"> Bharat AC-001 Bharat DC 001 Selection of DC charger connector GB/T, CHAdeMO, CCS-1 and CSS-2 Selection sizing of Charger connector cable 				Tesla Model 3 Charging Costs: Solar vs. Utility Ref:55 <ul style="list-style-type: none"> Demonstrate solar charging stations 			
	5	4,5	4	<ul style="list-style-type: none"> Installing a Solar At-Home EV Charger Ref 56 <ul style="list-style-type: none"> Install and Test solar powered EV charging station Solar powered EV charging station Ref 59 SRTPV powered charging station Ref 57	1		3	<ul style="list-style-type: none"> Advantages of utilizing RE sources for EV charging. Cost comparative analysis of RE based charging stations. Ref:50 <ul style="list-style-type: none"> Utilization of EVs for better RE Grid Integration Ref 58	1		2
			5	Developmental Assessment	-	-	-	Assessment Review and corrective action			3
			6	Industry Class + Assignment	2		3				
Week	CO	PO	Days	1st session (9am to 1 pm)	L	T	P	2ND session (1.30pm to 4.30pm)	L	T	P
9	4	1,4,5	1	Peer discussion on Industrial assignment.		4		Wind Energy Resources: <ul style="list-style-type: none"> Types of wind, wind profiling, turbulence, hill, and tunnel effect. Demonstrate Wind energy resources: Types of wind, wind profiling, turbulence, and hill and tunnel effect. Measure wind speed at different time period during day using 	1		2

								<p>anemometer and calculate wind pattern factor.</p> <ul style="list-style-type: none"> • Energy in the wind, energy production and simple problems • Energy and Power, Energy Pattern factor, simple problems 			
4	1,5	2	<p>Wind Power Plant</p> <ul style="list-style-type: none"> • Classification of wind power plant • Wind turbine classes. <p>Study of parts of Wind power plant:</p> <ul style="list-style-type: none"> • Rotor nacelle, tower, • High speed and low speed shafts, • Gear box, • Generator, • Sensors and yaw drive, • Power regulation and controlling units, • Safety systems. • Demonstrate working operation of each component of WPP 	3		1	<p>Wind Power Plant</p> <p>Wind energy conversion:</p> <ul style="list-style-type: none"> • Introduction • Rotating principle. • Drag and lift principle • Force on rotor blade • Factors affecting performance of rotor • Simple problems <p>Overview of Wind turbine Aerodynamics:</p> <ul style="list-style-type: none"> • Aerodynamic power regulation • Stall controlled WPP • Pitch controlled WPP • Active controlled WPP • Halting a WPP 	2		1	
4	1,3,5	3	<p>Wind turbine generators:</p> <ul style="list-style-type: none"> • Limited variable speed generator Type1 • Limited variable speed generator Type2 • Variable Speed with Partial Power Electronics conversion Type 3 • Variable Speed with Full Power Electronics Conversion Type4 • Demonstrate working and operation of each Wind turbine generators 	3		1	<p>Small Wind Turbines:</p> <ul style="list-style-type: none"> • Introduction • Small Wind Turbine Topologies • Need of SWT, SWT classification • Off-Grid SWT • On-grid SWT • Applications of SWT 	1		2	

				Ref:45				Ref:46			
	4	3,5	4	<ul style="list-style-type: none"> Estimate cost of a 1 KW horizontal/vertical wind turbine and Prepare a quotation Simulate Wind power plant model Ref:47	1		3	Perform a site survey at your location and prepare a feasibility report including <ul style="list-style-type: none"> Area availability Wind speed assessment wind profiling Demonstrate working of Traffic powered wind turbines Ref:48 Case studies on wind turbine 			3
	4		5	CIE 4- Written and practice test	-	-		Assessment Review and corrective action			3
			6	Industry Class + Assignment	2		3				
10	4	1,5	1	Peer discussion on Industrial assignment.		4		BIO ENERGY	2		1
								<ul style="list-style-type: none"> Bio mass as fuel for power generation Technological options to generate electricity by using biomass as fuel. Combustion Gasification Demonstration (Video/physical) of Bioenergy technologies. 			

							<ul style="list-style-type: none"> • Biomass based power plants Installed in Karnataka 			
4	1,4,5	2	<p>Biomass feedstock</p> <ul style="list-style-type: none"> • Agri and forest residues. • Industrial and domestic waste. • Food and food processing. • Waste, energy crops. • Sewage water and landfills. • Potential of Biomass: Energy (calorific value /hectare) • Relation between calorific value and efficiency • Biomass availability in Karnataka <p>Ref 60 Demonstration on Biomass feedstock Case study on biomass energy</p> <p>Ref 60b</p>	2		2	<ul style="list-style-type: none"> • Biogas- Benefits of Biogas, Biogas Feedstock, • Technology of Bio-gas production. • Biogas plant components, types of biogas digesters and plants. • Municipal Waste based Bio -gas plants-working, Advantages and disadvantages • Size and Site Selection for Biogas plant <p>Ref 61</p> <ul style="list-style-type: none"> • Construct a simple model of 10kg waste biogas plant in your campus. (from the waste available in campus only) 	1		2
4	1,4,5	3	<p>Biofuels: Classification by generation</p> <ul style="list-style-type: none"> • Bioethanol • Biodiesel • sustainable aviation fuel (SAF) <p>Renewable Natural Gas</p> <ul style="list-style-type: none"> • Renewable compressed natural gas (R-CNG) • Liquefied renewable natural gas (bio-LNG) <p>Bioethanol</p> <ul style="list-style-type: none"> • Production 	2		2	<ul style="list-style-type: none"> • Extraction of oil form algal biomass for biodiesel Production <p>Ref 62</p> <ul style="list-style-type: none"> • Algal biofuel from urban wastewater in India : <p>Ref 68</p> <ul style="list-style-type: none"> • The Algae House: Generating Energy 	1		2

			<ul style="list-style-type: none"> • Application Demonstrate production of Bioethanol Ref 63 Renewable Natural Gas <ul style="list-style-type: none"> • Production • Application Ref 64 sustainable aviation fuel (SAF) <ul style="list-style-type: none"> • Production of SAF • Importance of SAF • Saving of Carbon using SAF Ref 65 Biodiesel : <ul style="list-style-type: none"> • Production • Application Demonstrate production of Biodiesel : Ref 66 Algal biodiesel: the next generation biofuel for India <ul style="list-style-type: none"> • Algal biomass production in tubular photobioreactor • Innovative Approaches for improving algal biomass Yield Ref 67				from Living Algae on its Façade Ref 69 <ul style="list-style-type: none"> • Scope of IS 15607: Is standard for Biofuels Ref 70			
5	2,5	4	Feasibility study for a Biodiesel plant Ref:70			4	Design of 15 kW Micro Hydro Power Plant for Rural Electrification Ref:71 (Apply design thinking process)			3
		5	Developmental Assessment	-	-		Assessment Review and corrective action			3
		6	Industry Class + Assignment	2		3				

11	5	1,5	1	Peer discussion on Industrial assignment.	4		Introduction to Hydrogen Energy Hydrogen Production: Types of Electrolysers <ul style="list-style-type: none"> Alkaline Electrolyser Polymer electrolyte membrane Ref 78 Working of Solid oxide Electrolyser Ref 78 Specification of Solid oxide Electrolyzer. Color-coding of hydrogen based on the source of production Ref 78 Demonstration of (video) various hydrogen production methods.	2		1
	5	1,4,5	2	<ul style="list-style-type: none"> Hydrogen storage Hydrogen Transportation Production of Blue and Green Hydrogen Hydrogen End Use cost of Hydrogen production Ref 72 Demonstration of (video) hydrogen storage and transport 	2	2	<ul style="list-style-type: none"> Hydrogen Generation by Anaerobic Digestion of Biomass. Demonstrate Hydrogen Generation by Anaerobic Digestion of Biomass. Ref 73 Generating green hydrogen from biomass Ref 79 	2		3
	5	1,5	3	<ul style="list-style-type: none"> Utilization of Hydrogen gas Hydrogen as Alternate fuel for motor vehicles 	2	2	Design and simulate Fuel cell to produce power. Ref 76a.			2

				<p>Fuel cells</p> <ul style="list-style-type: none"> • Types of fuel cells • Characteristics of fuel cells • Comparison among different fuel cells. <p>Ref:86 Hydrogen fuel cell</p> <ul style="list-style-type: none"> • Working of hydrogen Fuel cell (Proton exchange membrane fuel cell) <p>Ref:87</p> <p>Fuel Cell Electric Vehicle</p> <ul style="list-style-type: none"> • Working of hydrogen engine <p>Ref 74</p> <ul style="list-style-type: none"> • The pros and cons of hydrogen-powered cars for users <p>Ref 75</p> <ul style="list-style-type: none"> • Hydrogen fuel cell cars: what you need to know <ul style="list-style-type: none"> • Hydrogen Fuel Cell Bus <p>Ref 76</p> <p>India's first Hydrogen fuel cell bus.</p> <p>Ref 88a</p> <p>Hydrogen powered Two wheeler.</p> <p>Ref 88b</p> <p>Application of fuel cell in Un manned Aircraft(UAV)</p> <ul style="list-style-type: none"> • 600U HYDROGEN FUEL CELL • 1200U HYDROGEN FUEL CELL <p>Ref 89 Hydrogen Trains Ref 90 Safety and management</p> <ul style="list-style-type: none"> • Causes of fires and preventive management. • Demonstrate the preventive management. 					
--	--	--	--	---	--	--	--	--	--

	5	1,5	4	<ul style="list-style-type: none"> • Specification of Electrolyzer and Fuel Cell • Test and Trouble shoot a Fuel cell Ref :76b <ul style="list-style-type: none"> • Run a Small DC motor using Hydrogen fuel Cell. Ref 91			4	Hydrogen Technology Development in India <ul style="list-style-type: none"> • Hydrogen initiatives of the ministry of petroleum & natural gas Ref 77a <ul style="list-style-type: none"> • A Green Hydrogen Economy for India: Ref 77 b -Demonstration of Hydrogen Technology in India <ul style="list-style-type: none"> • The Future of Hydrogen in India • Current cost economics of green hydrogen production in India • Future Price Trajectory of Green Hydrogen • Most optimistic green hydrogen price trajectory Ref77c	1		2
	5		5	CIE 5- Written and practice test	-	-	-	Assessment Review and corrective action			3
			6	Industry Class + Assignment	2		3				
12	5	1,5	1	Peer discussion on Industrial assignment.		4		Concept of energy storage <ul style="list-style-type: none"> • Classification of Storage Technologies. • Different Technologies for Different Purposes. • Comparison of Power Output (in watts) and Energy Consumption 	2		1

							(in watt-hours) for Various Energy Storage Technologies			
							<ul style="list-style-type: none"> • Differentiating Characteristics of different Battery Technologies • Present and Future Battery Technologies. • Discharge Time and Energy-to-Power Ratio of Different Battery Technologies 			
							Ref 80			
							<ul style="list-style-type: none"> • Demonstration of Different storage Technologies for Different Purposes. 			
5	1,5	2	<ul style="list-style-type: none"> • Components of a battery energy storage system (BESS) • Schematic of a Utility-Scale Energy Storage System. • Grid applications of battery energy storage systems. • Technical requirements: • Round-Trip Efficiency • Response Time • Lifetime and Cycling • Sizing • Frequency Regulation 	2	2	<p>Renewable Energy integration:</p> <ul style="list-style-type: none"> • Solar Photovoltaic Installation with a Storage System. • Wind-power generation. <p>Peak Shaving and Load Leveling:</p> <ul style="list-style-type: none"> • Use of Energy Storage Systems for Peak Shaving • Use of Energy Storage Systems for Load Leveling <p>Challenges of reducing carbon emissions:</p>	2		1	

									<ul style="list-style-type: none"> Energy Storage Services and Emission Reduction 			
	5	1,4,5	3	<ul style="list-style-type: none"> Gravity energy storage Characteristics Ref 82 <ul style="list-style-type: none"> Demonstrate Gravity energy storage Battery recycling and re-use risks: <ul style="list-style-type: none"> Examples of Battery Reuse and Recycling Reuse of Electric Vehicle Batteries for Energy Storage Ref 83 <ul style="list-style-type: none"> Demonstrate Reuse of Electric Vehicle Batteries for Energy Storage 	2		2	Micro-grids <ul style="list-style-type: none"> What are micro-grids Need for micro-grid Benefits of micro-grids Ref 84 <ul style="list-style-type: none"> Micro-grid projects in India Green Hydrogen Microgrid Project Ref 84b <ul style="list-style-type: none"> Micro-grid projects in Karnataka Simulation of small scale micro grid Ref 85	1		2	
	5	3,4,5	4	Perform feasibility study to suggest appropriate sustainable energy and energy storage solutions for an educational institute/commercial building/industry. -1			4	Perform feasibility study to suggest appropriate sustainable energy and energy storage solutions for an educational institute/commercial building/industry. -2			3	
			5	Developmental Assessment	-	-		Assessment Review and corrective action			3	
			6	Industry Class + Assignment	2		3					
Week	C O	P O	Days	1st session (9am to 1 pm)	L	T	P	2nd session (1.30pm to 4.30pm)	L	T	P	
13	1,2,3,4,5	2,3,4,5		Internship a) Secondary research on various industries and their operations to identify at least 3 companies along with the areas of work			4	Project a) Identification of the problem statement (from at least 3 known			3	

			<p>interest and develop an internship plan that clearly highlights expectations from the industry during the internship.</p> <p>b) Design and develop a cover letter for an internship request to all 3 identified companies and the resume to be submitted to potential companies.</p> <p>c) Prepare for an internship interview to highlight your interests, areas of study, career aspirations and personnel competence – including the areas of learning you expect to learn during internship</p>			<p>problems) the students would like to work as part of the project – either as provided by faculty or as identified by the student. Document the impact the project will have from a technical, social and business perspective.</p> <p>b) Design and develop the project solution or methodology to be used to solve at least one of the problems identified.</p> <p>Prepare a project plan that will include a schedule, WBS, Budget and known risks along with strategies to mitigate them to ensure the project achieves the desired outcome.</p>			
--	--	--	--	--	--	--	--	--	--

References:

Sl No	Description	
1	Introduction to sustainability	https://www.twi-global.com/technical-knowledge/faqs/faq-what-is-sustainability#WhyisitImportanttobeSustainable
2	Seventeen Sustainable Development Goals	https://sdgs.un.org/goals
3	Sustainability Carbon footprint calculator	https://www.tatapower.com/sustainability/sustainability-initiatives/customer/calculate-carbon-footprints.aspx
4	Sustainable Manufacturing for India's Low-Carbon Transition	https://www.ceew.in/publications/sustainable-manufacturing-indias-low-carbon-transition
5	Power-Positive	a. https://www.indoasiancommodities.com/2022/03/03/kochi-airport-to-become-power-positive-with-its-new-solar-plant/ b. https://energy.economictimes.indiatimes.com/news/renewable/airport-in-kochi-to-become-power-positive-with-new-solar-plant-from-march-6/89882448
6	Prepare table: (Karnataka): Installed capacity for thermal, hydro, nuclear and Renewable. Electricity Price & Availability	a. https://npp.gov.in/dashBoard/cp-map-dashboard b. https://www.vidyutpravah.in/
7	Design thinking	a. https://careerfoundry.com/en/blog/ux-design/design-thinking-examples/ b. https://online.hbs.edu/blog/post/design-thinking-examples c. https://www.healing-power-of-art.org/positive-art-news-creativity-turns-scary-mri-scanner-for-kids-into-an-adventure/ Examples of design thinking d. https://careerfoundry.com/en/blog/ux-design/design-thinking-examples/ e. https://online.hbs.edu/blog/post/design-thinking-examples f. https://www.healing-power-of-art.org/positive-art-news-creativity-turns-scary-mri-scanner-for-kids-into-an-adventure/ g. https://www.linkedin.com/pulse/how-can-design-thinking-help-utilities-prepare-new-energy-singh h. https://thisisdesignthinking.net/2016/05/reinventing-solar-energy-supply-for-rural-africa/ i. http://innodigest.com/design-thinking-to-sustainable-energy/
8	Agrovoltaics	a. https://www.iberdrola.com/innovation/agrovoltaics b. https://agrovoltaic.org/solar-greenhouses/ c. https://agrovoltaic.org/ground-mounted/

		d. https://agrovoltaic.org/elevated-photovoltaic-panels/ e. https://agrovoltaic.org/benefits-of-agrovoltaics/ f. https://greencoast.org/agrivoltaics/
9	Terminology used in the Solar Industry	https://us.sunpower.com/what-solar-energy-glossary-common-solar-terms
10	BIPV(Building-integrated photovoltaics)	https://www.seia.org/initiatives/building-integrated-photovoltaics .
11	Half cut solar cell technology	https://www.solarreviews.com/blog/half-cut-solar-cell-technology-explained#advantages
12	Monocrystalline, polycrystalline, thin film	https://www.solarreviews.com/blog/pros-and-cons-of-monocrystalline-vs-polycrystalline-solar-panels#types-of-solar-panels-performance
13	Specification of solar panel	https://www.altestore.com/blog/2016/04/how-do-i-read-specifications-of-my-solar-panel/#.YjWCNOpBy3A
14	Product list	https://ae-solar.com/products-list/
15	Solar Panel sizing	a. https://electrical-engineering-portal.com/download-center/electrical-ms-excel-spreadsheets b https://electrical-engineering-portal.com/download-center/electrical-software/calculate-size-of-solar-panel-battery-bank-inverter
16	C- and E- rates:	https://batteryuniversity.com/article/bu-402-what-is-c-rate
17	A Guide to Understanding Battery Specifications	http://web.mit.edu/evt/summary_battery_specifications.pdf
18	Select a suitable battery for given application:	a. https://www.dfrsolutions.com/blog/how-to-select-the-right-battery-for-your-application-part-1-battery-metric-considerations b. https://www.dfrsolutions.com/hubfs/Blog_Images/secondary-battery-properties.jpg
19	Battery Sizing Calculation:	https://simpliphpower.com/company/news/blog/heres-a-crash-course-in-battery-system-sizing/#:~:text=The%20most%20important%20step%20when,be%20supported%20by%20the%20system.
20	Battery Sizing Guidelines	https://www.trojanbattery.com › pdf › TRJN0168.
21	solar panel in simulation	https://youtu.be/O9nhpdRBVX8
22	Simulation of Solar power generation for home using any software	https://youtu.be/cHYOQGIlQss
23	Charge controllers:	a. https://www.renogy.com/learn-charge-controller-types/ b. https://sinovoltaics.com/learning-center/components/solar-charge-controllers-need-know/ c. Identification of charge controller and its applications

24	Power Optimizer	d. https://www.windynation.com/cm/Testing%20a%20Solar%20System_R1.pdf https://www.solaredge.com/products/power-optimizers
25	Connectors used in Solar module	https://fluxconnectivity.com/what-is-an-mc4-connector/
26	MC4 Connector Specifications	https://www.solar-electric.com/learning-center/how-to-use-mc4-connectors-cables.html/#:~:text=There%20are%20two%20different%20multibranch,MC4%20connector%20for%20its%20output
27	Solar branch connectors	https://www.leadergroup-cn.com/leader-connector/solar-branch-connector/2-in-1-t-branch-connector
28	Sizing of DC cable	a. https://www.windynation.com/jzv/inf/choosing-right-wire-size b. https://www.ppa.org/fj/uploads/2020/10/Det...
29	Solar Inverters	a. https://search.abb.com/library/Download.aspx?DocumentID=9AKK107492A3277&LanguageCode=en&DocumentPartId=&Action=Launch b. https://search.abb.com/library/Download.aspx?DocumentID=9AKK107492A3277&LanguageCode=en&DocumentPartId=&Action=Launch c. https://www.wikihow.com/Choose-a-Solar-Inverter d. www.temco.co.in
30	Mounting of Solar Panels	a. https://greentumble.com/types-of-solar-panel-mounting-systems-and-their-installation/ b. https://www.e-education.psu.edu/ae868/node/913 c. https://www.altestore.com/diy-solar-resources/selecting-your-solar-module-mounting-structure/
31	Design of off-grid rooftop PV System for a residence/commercial building	https://www.aurorasolar.com/blog/how-to-size-a-pv-system-from-an-electricity-bill/
32	Design 100 KW solar PV system	https://www.researchgate.net/figure/Cost-and-bill-of-material-for-a-500-kWp-solar-PV-plant-with-solar-smoother-and-battery_tbl6_323944719
33	PV MPPT simulation	https://youtu.be/LMOMeppPS-Y
34	3MW grid connected by PV system	https://youtu.be/ZXs_lg0daRc
35	Measure Insulation resistance and Wet Leakage Current of PV Modules.	https://sinovoltaics.com/wet-leakage-current-testing/
36	Hot-spot on modules through audio visual aids.	https://solarpost.in/om/solar-panel-hot-spot-causes-effects/
37	Maintain Solar Photovoltaic System	https://mercomindia.com/robotic-cleaning-maximize-energy-yield/
38	Case study on solar system	https://www.tatapowersolar.com/project/2-67-mw-solar-plant-carport-cochin-international-airport-ltd/ https://www.academia.edu/5449881/Design_and_Estimation_of_1MW_utility_Scale_Solar_PV_Power_Plant_Technical_and_Financial_UPDATED
39	Design and implement solar Street Light system	https://www.engoplanet.com/single-post/2017/08/21/how-to-design-and-calculate-solar-street-light-system

40	Case study of 2GW solar power plant at Pavagada solar park	https://www.power-technology.com/projects/pavagada-solar-park-karnata3ka/
41	Power Evacuation Scheme	https://kspdcl.karnataka.gov.in/english#
42	Design and implement solar pumping system and Flourmill	a. https://www.electricaltechnology.org/2020/09/design-solar-photovoltaic-powered-dc-water-pump.html b. https://www.thebetterindia.com/293978/flour-mill-in-uttar-pradesh-pays-zero-electricity-bills-with-solar-panels/amp/#aoh=16601115246518&csi=0&referrer=https%3A%2F%2Fwww.google.com&amp_tf=From%20%251%24s
43	SCADA	https://nptel.ac.in/courses/108106022
44	Solar energy SCADA system	https://www.stability.co/centralized-scada-system-for-solar-power-plants/
45	Wind turbine generators	www.site.uottawa.ca > ELG4126WindGenerators
46	Small Wind Turbines	https://www.wind-energy-the-facts.org/markets-and-applications-for-small-wind-turbines.html
47	Simulate Wind power plant model	https://youtu.be/5QEof5HXF8
48	Demonstrate working of Traffic powered wind turbines	a. https://www.goodnewsnetwork.org/onshore-wind-turbines-powered-by-traffic/ b. https://www.shell.com/inside-energy/turbine-turns-traffic-into-energy.html c. https://highways.today/2020/04/09/highway-wind-turbines/ d. https://www.euronews.com/green/2021/11/04/turning-traffic-into-clean-energy-how-this-startup-plans-to-power-the-streets-of-istanbul e. www.osti.gov > biblio > 1225476-small-wind-site
49	Renewable Sources of Electricity to charge Electric Vehicles	https://e-vehicleinfo.com/charging-an-ev-using-renewable-energy-solar-wind/
50	Technical Details of EV charger	https://e-amrit.niti.gov.in/assets/admin/dist/img/new-fronend-img/report-pdf/Report1-Fundamentals-ofElectricVehicleChargingTechnology-and-its-Grid-Integration_GIZ-IITB.pdf
51	Power Converters are needed for Charging Electric Cars from PV and wind?	https://e-vehicleinfo.com/charging-an-ev-using-renewable-energy-solar-wind/
52	Selection of charger for given vehicle type, power rating and voltage	https://e-amrit.niti.gov.in/standards-and-specifications
53	Solar charging stations for electric vehicles (EV's)	https://sinovoltaics.com/learning-center/electric-vehicles/solar-and-electric-vehicles-part-1/
54	How Many Solar Panels Does It Take to Charge an Electric Car?	https://www.solar.com/learn/how-many-solar-panels-does-it-take-to-fuel-an-electric-car/
55	Tesla Model 3 Charging Costs: Solar vs. Utility	https://www.solar.com/learn/cost-to-charge-a-tesla-model-3-with-solar-vs-social-edison/
56	Installing a Solar At-Home EV Charger	a. https://electriccitycorp.com/solar-ev-charging-station/ b. https://www.buildwithrise.com/stories/how-to-set-up-a-home-solar-pv-system-to-power-an-electric-car

57	SRTPV powered charging station	https://indiasmartgrid.org/reports/BESCOM%20EVCI%20Planning%20and%20Rollout%20for%20Bengaluru%20City,%20Karnataka.pdf
58	Utilization of EVs for better RE Grid Integration	https://indiasmartgrid.org/reports/BESCOM%20EVCI%20Planning%20and%20Rollout%20for%20Bengaluru%20City,%20Karnataka.pdf
59	Solar powered EV charging station	https://youtu.be/DR2yEf20wY4
60	Biomass availability in Karnataka	a. https://karunadu.karnataka.gov.in/kercc/Reports/StudyOnTheSustainabilityOfBio-massBasedPowerGenerationInKarnataka.pdf b. https://www.ijert.org/a-case-study-on-generation-of-biomass-energy-using-agriculture-residue
61	Size and Site Selection for Biogas plant	https://sobac.com/~stopthestink/guidelines for selecting suitable sites for biogas plants/
62	Extraction of oil form algal biomass for biodiesel Production	https://www.ncbi.nlm.nih.gov/pmc/articles/PMC3152439/
63	Production of Bioethanol	https://youtu.be/A9BB-A2uc0I
64	Renewable Natural Gas	https://afdc.energy.gov/fuels/natural_gas_renewable.html
65	Sustainable aviation fuel (SAF)	a. https://aviationbenefits.org/environmental-efficiency/climate-action/sustainable-aviation-fuel/producing-sustainable-aviation-fuel/ b. https://simpleflying.com/rolls-royce-2-3-million-liters-saf/ b. https://www.bp.com/en/global/air-bp/news-and-views/views/what-is-sustainable-aviation-fuel-saf-and-why-is-it-important.html
66	Production of Biodiesel	https://youtu.be/xLa83KlaEyw
67	Algal Biodiesel	a. https://www.energy.gov/eere/bioenergy/advanced-algal-systems b. https://www.researchgate.net/publication/259677327 Algal Biodiesel The next generation biofuel for India/link/546406190cf2c0c6aec4fc0b/download c. https://www.energy.gov/eere/bioenergy/advanced-algal-systems
68	Algal Biofuel From Urban Wastewater In India	http://wgbis.ces.iisc.ernet.in/energy/paper/rsr_algal_biofuel/introduction.htm
69	The Algae House	https://www.rockwellautomation.com/en-in/company/news/case-studies/the-algae-house--generating-energy-from-living-algae-on-its-faca.html
70	Scope of IS 15607 : Is standard for Biofuels Feasibility study for a Biodiesel plant	https://law.resource.org/pub/in/bis/S11/is.15607.2005.pdf a. https://biodieseleducation.org/Literature/Journal/2006 Crockett Feasibility study fo.pdf b. https://gis.penndot.gov/BPR_PDF_FILES/Documents/Research/Complete%20Projects/Planning/Biodiesel%20Fuel%20Feasibility%20Study.pdf
71	Design of 15 kW Micro Hydro Power Plant for Rural Electrification	https://www.sciencedirect.com/science/article/p

72	Hydrogen storage	<p>a. https://www.crowcon.com/blog/blue-hydrogen-an-overview/ b. https://hydrogen-central.com/india-reliance-industries-blue-hydrogen-maker/ c. https://www.msn.com/en-in/money/topstories/reliance-industries-aims-to-become-world-s-top-blue-hydrogen-maker/ar-AAT0xBv d. https://www.ndtv.com/business/indian-oil-corp-forms-joint-ventures-for-green-hydrogen-electrolyser-2861409 e. https://www.shell.com/energy-and-innovation/new-energies/hydrogen.html f. https://youtu.be/AQqeo2-Z 3A</p> <p>g. https://youtu.be/Bq4bZCq24Hg</p> <p>h. Harnessing-Green-Hydrogen V21_DIGITAL_29_06.pdf (niti.gov.in)</p> <p>i. https://www.straitstimes.com/singapore/environment/new-25-million-research-institute-to-bring-green-hydrogen-from-lab-to-society</p> <p>j. https://blog.forumias.com/national-hydrogen-energy-mission-nhem/</p>
73	Hydrogen Generation by Anaerobic Digestion of Biomass	<p>a. http://www.sentientlabs.in/ b. https://edinburghsensors.com/news-and-events/using-anaerobic-biomass-digestion-produce-hydrogen-biofuel/</p>
74	Fuel Cell Electric Vehicle	https://auto.economictimes.indiatimes.com/news/passenger-vehicle/cars/investment-in-hydrogen-fuel-falls-20-in-2020-fuel-cell-vehicle-demand-to-be-fragile/82575173
75	Hydrogen-powered cars	<p>a. https://www.bmw.com/en/innovation/how-hydrogen-fuel-cell-cars-work.html b. https://www.fchea.org/transportation</p>
76	Hydrogen Fuel Cell Bus	https://sentientlabs.in/
76a	Design and simulate Fuel cell	https://youtu.be/lbn_3ouUCwA
76b	Test and Trouble shoot Fuel cell	https://www.fuelcellstore.com/fuel-cell-stacks/low-power-fuel-cell-stack
77	A Green Hydrogen Economy for India:	<p>a. https://mopng.gov.in/en/page/12 b. https://www.ceew.in/publications/reducing-green-hydrogen-production-cost-in-india c. Harnessing-Green- Hydrogen V21_DIGITAL_29_06.pdf (niti.gov.in)</p>
78	Introduction to hydrogen energy	<p>https://www.sciencedirect.com/topics/engineering/electrolyzer https://www.bloomenergy.com/wp-content/uploads/Data-Sheet Bloom-Electrolyzer-10-MW UPDATED-6.24.22.pdf https://www.iberdrola.com/sustainability/electrolyzer Harnessing-Green- Hydrogen V21_DIGITAL_29_06.pdf (niti.gov.in)</p>
79	Generating green hydrogen from biomass	https://iisc.ac.in/events/generating-green-hydrogen-from-biomass-an-abundant-renewable-energy-source/

80	Hand book of energy storage	www.adb.org/sites/default/files/publication/479891/handbook-battery-energy-storage-system.pdf
81	Challenges of reducing carbon emissions	www.adb.org/sites/default/files/publication/479891/handbook-battery-energy-storage-system.pdf
82	Gravity energy storage	a. https://gravitricity.com/technology/ b. https://www.eqmagpro.com/gravitricity-is-go-energy-storage-pioneer-commissions-demonstration-project/
83	Battery recycling and reuse risks	www.adb.org/sites/default/files/publication/479891/handbook-battery-energy-storage-system.pdf
84	Micro-grids	a. https://www.weforum.org/agenda/2022/05/what-are-microgrids-renewable-power/ b. https://www.ntpc.co.in/en/media/press-releases/details/ntpc-awards-india%E2%80%99s-first-green-hydrogen-microgrid-project
85	Simulation of small scale micro grid	https://youtu.be/800-t69bI-E
86	Fuel cells	https://new.abb.com/news/detail/31259/the-fuel-cell-a-green-powerhouse
87	Hydrogen fuel cell	https://fuelcellsworks.com/knowledge/technologies/pemfc/ https://www.sciencebuddies.org/science-fair-projects/project-ideas/Energy_p002/energy-power/fuel-cells#procedure
88	Hydrogen fuel cell bus. Hydrogen powered Two wheeler	a. https://indianexpress.com/article/technology/science/hydrogen-fuel-cell-electric-bus-8104087/ b. https://auto.hindustantimes.com/auto/two-wheelers/tesla-rival-triton-ev-to-launch-hydrogen-fuel-two-wheelers-in-india-41658561332418.html
89	Application of fuel cell	https://aerospace.honeywell.com/us/en/learn/products/honeywell-hydrogen-fuel-cell
90	Hydrogen Trains	https://www.mobility.siemens.com/global/en/portfolio/rail/rolling-stock/commuter-and-regional-trains/hybrid-drive-systems/mireo-plus-h.html
91	Hydrogen fuel Cell.	https://www.sciencebuddies.org/science-fair-projects/project-ideas/Energy_p002/energy-power/fuel-cells#procedure
92	Infosys Springboard: Course on Solar Energy Basics	https://infyspringboard.onwingspan.com/web/en/app/toc/lex_auth_013267711536734208503/overview

CIE and SEE Assessment Methodologies

CIE Assessment	Assessment Mode	Duration In hours	Max Marks
Week 3	CIE 1- Written and practice test	4	30
Week 5	CIE 2- Written and practice test	4	30
Week 7	CIE 3- Written and practice test	4	30
Week 9	CIE 4- Written and practice test	4	30
Week 11	CIE 5- Written and practice test	4	30
	On line Course work (Minimum 10 hours online course with certification from (SWAYAM/NPTEL/Infosys Springboard)		40
	Profile building for Internship / Submission of Synopsys for project work		20
Portfolio evaluation (Based on industrial assignments and weekly developmental assessment) *			30
TOTAL CIE MARKS (A)			240
SEE 1 - Theory exam (QP from BTE) Conducted for 100 marks 3 hrs duration reduced to 60 marks		3	60
SEE 2 - Practical		3	100
TOTAL SEE MARKS (B)			160
TOTAL MARKS (A+B)			400

* The industrial assignment shall be based on peer-to-peer assessment for a total of 10 marks (on a scale of 1 to 10) and in the event of a group assignment the marks awarded will be the same for the entire group, the developmental assessment will be for a total of 20 marks and based on MCQ/case study/demonstration and such other assignment methods

Assessment framework for CIE (1 to 5)

Note: Theory to be conducted for 1 hour and practice for 3 hours, total duration of exam – 4 hours

Programme	Electrical & Electronics Engineering	Semester	V		
Course	Renewable Energy	Max Marks	30		
Course Code	20EE53I	Duration	4 hours		
Name of the course coordinator					
Note: Answer one full question from each section.					
Qn.No	Question	CL L3/L4	CO	PO	Marks
Section-1 (Theory) – 10 marks					
1.a)	Select a suitable PV system for a domestic purpose to sell excess power to grid by a. configuration, b. deployment c. solar panel with specification With proper justification.	L3	1	1	10
2.a)	Size the solar panel and charge controller for 3kW solar PV system	L3		2	10
Section-2 (Practical) - 20 marks					
1)a	Test the following for the good condition 1. Solar panel 2. Charge controller 3. Battery 4. Inverter	L3	1	4	15
b.	Find out the following from the given solar panel/datasheet 1. Voc 2. Isc 3. Pmax 4. Model Efficiency	L3	1	1	5

Note : Theory questions shall be aligned to practical questions

Assessment framework for SEE 1 (Theory)

Programme :	Electrical & Electronics Engineering						Max Marks :	100																																																	
Semester :	V						Duration :	3 Hrs																																																	
Course :	Renewable Energy																																																								
Course Code :	20EE53I																																																								
Instruction to the Candidate: Answer one full question from each section.																																																									
Q.No	Question							CL	CO	Marks																																															
Section-1																																																									
1	<p>A house consists of the following load: Design an off-grid solar PV system. Identify main components, calculate panel wattage b. Number of modules in series -parallel combination. c. Battery sizing d. Charge controller rating e. cable wiring.</p> <table border="1"> <thead> <tr> <th rowspan="2">Floor</th> <th rowspan="2">Room Type (kitchen, hall, garden, etc)</th> <th rowspan="2">Load type (ex: motor, pump, etc)</th> <th rowspan="2">AC or DC</th> <th rowspan="2">Load Wattage (ex: 20W)</th> <th rowspan="2">No. of applian ces</th> <th rowspan="2">Hours of usage/ day</th> <th colspan="2">Usage mainly Day or Night?</th> </tr> <tr> <th>Day time usage</th> <th>Night time usag e</th> </tr> </thead> <tbody> <tr> <td>Ground</td> <td>Small room</td> <td>1 LED light</td> <td>DC</td> <td>5 W</td> <td>1</td> <td>2 hours</td> <td>1</td> <td>1</td> </tr> <tr> <td>Ground</td> <td>Small room</td> <td>1 LED light</td> <td>DC</td> <td>2 W</td> <td>1</td> <td>4 hours</td> <td>1</td> <td>3</td> </tr> <tr> <td>Ground</td> <td>Small room</td> <td>1 LED light</td> <td>DC</td> <td>4 W</td> <td>1</td> <td>3 hours</td> <td>1</td> <td>2</td> </tr> <tr> <td>Ground</td> <td>Small room</td> <td>Fan</td> <td>DC</td> <td>18 W</td> <td>1</td> <td>8 hours</td> <td>4</td> <td>4</td> </tr> </tbody> </table>							Floor	Room Type (kitchen, hall, garden, etc)	Load type (ex: motor, pump, etc)	AC or DC	Load Wattage (ex: 20W)	No. of applian ces	Hours of usage/ day	Usage mainly Day or Night?		Day time usage	Night time usag e	Ground	Small room	1 LED light	DC	5 W	1	2 hours	1	1	Ground	Small room	1 LED light	DC	2 W	1	4 hours	1	3	Ground	Small room	1 LED light	DC	4 W	1	3 hours	1	2	Ground	Small room	Fan	DC	18 W	1	8 hours	4	4	L4	1	20
Floor	Room Type (kitchen, hall, garden, etc)	Load type (ex: motor, pump, etc)	AC or DC	Load Wattage (ex: 20W)	No. of applian ces	Hours of usage/ day	Usage mainly Day or Night?																																																		
							Day time usage	Night time usag e																																																	
Ground	Small room	1 LED light	DC	5 W	1	2 hours	1	1																																																	
Ground	Small room	1 LED light	DC	2 W	1	4 hours	1	3																																																	
Ground	Small room	1 LED light	DC	4 W	1	3 hours	1	2																																																	
Ground	Small room	Fan	DC	18 W	1	8 hours	4	4																																																	
2.a)	Customer wants to buy charge controller for his 3kw rooftop PV system. what type of charge controller and its rating you recommend the customer . Justify your recommendation							L3	5																																																
b)	<p>A solar panel has following specifications</p> <table border="1"> <tbody> <tr> <td>V_{oc}</td> <td>43.42V</td> </tr> <tr> <td>I_{sc}</td> <td>4.48A</td> </tr> <tr> <td>V_{mp}</td> <td>35.82V</td> </tr> <tr> <td>I_{mp}</td> <td>4.26A</td> </tr> </tbody> </table>							V_{oc}	43.42V	I_{sc}	4.48A	V_{mp}	35.82V	I_{mp}	4.26A	L3	5																																								
V_{oc}	43.42V																																																								
I_{sc}	4.48A																																																								
V_{mp}	35.82V																																																								
I_{mp}	4.26A																																																								

	Calculate the peak capacity of the capacity of the panel and the energy generated considering the effective sunshine hours to be 5 hours.			
c)	Design a solar powered DC water pump where we need 50 m ³ water per day from a depth of 20 m. It has elevation, standing water level, and drawdown of 10 m, 10 m, and 4 m respectively. Water density is 2000 kg/m ³ and acceleration due to gravity (g) is 9.8 m ² /s. The peak power rating of the solar module is 36 WP, as the modules do not operate at its rated peak power capacity, operating factor is 0.75. The pump efficiency is around 40 % and the mismatch factor is 0.85 as the modules do not operate at the maximum PowerPoint.	L4		10
Section-2				
3.a)	Suggest troubleshooting procedures and corrective actions for Solar PV system for the following faults. 1. The system works but runs out of power too quickly 2. The system stops working 3. Power output is low	L4		15
b)	For solar plants capacity 2GW, how will you optimize operation and maintenance process .Suggest any innovative method to increase cleaning cycle 24 to 365, to increase operational efficiency.	L4		5
4.a)	Management of thousands of solar panels on the field was a challenge. As the assets were being managed manually, it required the investment of a lot of manpower. Hence the customer desired to optimize and automate the tracking, monitoring and configuration activities of all the assets of the plant, including solar panels and various electric motors. 1. Why was the Current Method of Monitoring Assets not efficient? 2. What was required to overcome the Limitations of Manual Monitoring and Achieve the Desired outcome? 3. How to automate tracking, monitoring and configuration activities of all the assets of the solar power plant. 4. List key highlights of your solution.	L4	2	10
b)	For 2 GW solar plant which communication protocol you recommend for SCADA. Justify your recommendation. Can you Suggest typical SCADA hardware and software required for the plant?	L3		10
Section- 3				

5.a)	Differentiate between level 1, Level 2 and Level 3 charging. Select suitable charging levels for Two wheelers and Four wheeler vehicle. Select type connectors for only DC charging .	L3	3	10
b)	How Many Solar Panels does it take to Charge an Electric Car? Justify your answer with calculations	L4		5
c)	Compare charging costs Solar vs. Utility	L4		5
6.a)	Is Keeping RE sources and Battery energy storage systems (BESS) systems in EV charging stations techno-economically feasible? Justify the statement with facts and figures	L4		10
b)	Can you Use EV for Better RE grid integration? Justify your answer	L4		10

Section-4

7.a)	<table border="1"> <tr> <th colspan="2">KITTERY</th> </tr> <tr> <td>Turbine Information</td> <td></td> </tr> <tr> <td>Model</td> <td>Entegrity EW50</td> </tr> <tr> <td>Capacity</td> <td>50-kilowatts (kW) 177-m² swept area</td> </tr> <tr> <td>Tower Height</td> <td>125-ft lattice tower</td> </tr> <tr> <td>Site Characteristics</td> <td></td> </tr> <tr> <td>Elevation</td> <td>~26.8 meters (m) 43.119/-70.749</td> </tr> <tr> <td>Latitude/Longitude</td> <td></td> </tr> <tr> <td>Surrounding Terrain/ Obstacles</td> <td>Developed on the crest of a hill, above some trees at the town transfer station with a big gap facing the principal wind direction down by the river (see wind rose B-6); trees are 70 ft high in the area</td> </tr> <tr> <td>Performance</td> <td></td> </tr> <tr> <td>Estimate (kWh)</td> <td>58,000 kilowatt-hours (kWh) annually¹⁵</td> </tr> <tr> <td>Actual (KWh)</td> <td>~35,000 kWh/year (yr.)¹⁶ (approx. 60% of estimate)</td> </tr> <tr> <td>Maintenance Issues</td> <td>Main brakes malfunctioned, locking the blades in place</td> </tr> <tr> <td>Current Operating Status</td> <td>Turbine is still located at the transfer station, but does not currently generate energy¹⁷</td> </tr> </table> <p>Study the above case and answer the following questions.</p> <p>1. Does the presence of seventy-foot trees in the vicinity of the Kittery project has any effect of wind turbine performance?</p>	KITTERY		Turbine Information		Model	Entegrity EW50	Capacity	50-kilowatts (kW) 177-m ² swept area	Tower Height	125-ft lattice tower	Site Characteristics		Elevation	~26.8 meters (m) 43.119/-70.749	Latitude/Longitude		Surrounding Terrain/ Obstacles	Developed on the crest of a hill, above some trees at the town transfer station with a big gap facing the principal wind direction down by the river (see wind rose B-6); trees are 70 ft high in the area	Performance		Estimate (kWh)	58,000 kilowatt-hours (kWh) annually ¹⁵	Actual (KWh)	~35,000 kWh/year (yr.) ¹⁶ (approx. 60% of estimate)	Maintenance Issues	Main brakes malfunctioned, locking the blades in place	Current Operating Status	Turbine is still located at the transfer station, but does not currently generate energy ¹⁷	L4	4	10
KITTERY																																
Turbine Information																																
Model	Entegrity EW50																															
Capacity	50-kilowatts (kW) 177-m ² swept area																															
Tower Height	125-ft lattice tower																															
Site Characteristics																																
Elevation	~26.8 meters (m) 43.119/-70.749																															
Latitude/Longitude																																
Surrounding Terrain/ Obstacles	Developed on the crest of a hill, above some trees at the town transfer station with a big gap facing the principal wind direction down by the river (see wind rose B-6); trees are 70 ft high in the area																															
Performance																																
Estimate (kWh)	58,000 kilowatt-hours (kWh) annually ¹⁵																															
Actual (KWh)	~35,000 kWh/year (yr.) ¹⁶ (approx. 60% of estimate)																															
Maintenance Issues	Main brakes malfunctioned, locking the blades in place																															
Current Operating Status	Turbine is still located at the transfer station, but does not currently generate energy ¹⁷																															

	<p>2. In case of Kittery project what is not considered in site-evaluation and selection.</p> <p>3. Does the presence of ground clutter in Kittery project affect life span of wind turbine?</p> <p>4. Does ground clutter influence a project's annual energy output?</p> <p>5. What do you suggest to improve annual energy output of wind turbine?</p>																											
b)	<p>Calculate the power developed and speed in rpm for a small wind turbine generator with the following particulars.</p> <p>Rotor efficiency =40%</p> <p>Generator efficiency =70 %</p> <p>Rotor swept area =2.11 m²</p> <p>Wind speed = 8.6 m/s</p> <p>Tip Speed Ratio =7</p> <p>Radius of rotor = 0.82 m</p>	L3		10																								
8.a)	<table border="1"> <thead> <tr> <th>Sr.no</th> <th>Sample</th> <th>Calorific value(KCAL)</th> <th>Efficiency (%)</th> </tr> </thead> <tbody> <tr> <td>1</td> <td>Straw</td> <td>3061.30</td> <td>47</td> </tr> <tr> <td>2</td> <td>Cow dung</td> <td>3123</td> <td>46</td> </tr> <tr> <td>3</td> <td>Sawdust</td> <td>3141.86</td> <td>45</td> </tr> <tr> <td>4</td> <td>Cotton stick</td> <td>3770.23</td> <td>38</td> </tr> <tr> <td>5</td> <td>Coal</td> <td>6500</td> <td>22</td> </tr> </tbody> </table> <p>Study the above table which shows calorific values and efficiency for different samples and answer the following questions.</p> <ol style="list-style-type: none"> Which samples are good enough to be used in biomass power plant for power generation and why What is the inference you draw from the above table. Which sample suits best and which suits least for biomass power generation with proper reasoning. 	Sr.no	Sample	Calorific value(KCAL)	Efficiency (%)	1	Straw	3061.30	47	2	Cow dung	3123	46	3	Sawdust	3141.86	45	4	Cotton stick	3770.23	38	5	Coal	6500	22	L4		10
Sr.no	Sample	Calorific value(KCAL)	Efficiency (%)																									
1	Straw	3061.30	47																									
2	Cow dung	3123	46																									
3	Sawdust	3141.86	45																									
4	Cotton stick	3770.23	38																									
5	Coal	6500	22																									
b)	Discuss Innovative Approaches for improving algal biomass Yield	L4		5																								
c)	Discuss any one method of extraction of oil from algal biomass for biodiesel Production	L4		5																								
Section-5																												
9.a)	Can we use green hydrogen on a massive scale? Justify your answer	L4	5	5																								
b)	Is a fuel cell vehicle the same as an electric vehicle? Justify your answer	L4		5																								

c)	Name the device or process used to produce hydrogen. How will you produce hydrogen in cost-effective manner?	L4		5
d)	Suggest suitable storage solutions to store electrical energy generated 1MW floating solar PV system.	L4		5
10.a)	Is producing green hydrogen profitable at present? How can it made profitable in future, Suggest changes in technology to be made to make it profitable.	L4		5
b)	Is hydrogen a sustainable fuel? Justify your answer. OR What are the potential challenges for Green hydrogen?	L4		5
c)	India's Largest integrated energy company has awarded project of "Stand alone Fuel cell based Microgrid with green hydrogen production using electrolyser at NTPC Simhadri. This will be India's first Green Hydrogen based Energy storage project and one of World largest. 1. Which type of Electrolyze would you think could be used in this project and its rating in KW 2. What is the source of Input power to Electrolyze. 3. How hydrogen energy could be stored in this project. 4. Draw a single line diagram of this microgrid project.	L4		5
d)	How will you use design thinking process to setup hydrogen fuelling station in your city.	L4		5

Scheme of Evaluation for SEE 2

Sl. No	Description	Marks
1	Identify charging level, plugs, connectors, sockets as per given requirements	10
2	Design install, commission, test and trouble shoot solar PV system as per customer requirements.	40
3	Simulation exercise on solar/SCADA/wind/Fuel cell/micro grid	30
4	Feasibility study report to suggest appropriate sustainable energy and energy storage solutions for an educational institute/commercial building/industry.	10
5	Viva voce	10
Total		100

Required Equipment/software list with Specification

Sl. No.	Particulars	Specification	Quantity
1	3kW offgrid rooftop solar PV system with Battery backup	3kW	1
2	5kW ongrid rooftop solar PV system	5kW	1
3	Pyranometer		1
4	Solar Insulation meter		3
5	Rooftop Mounting Structure For 4 x 250 W solar panels mounting practice, with tilt adjustment		2 set
6	Weather monitoring station	To monitor and record Sunshine, wind velocity, temperature, rainfall etc with software.	1
7	Solar cell based sunlight radiation meter	For Solar power measurement up to 2000 w/square meter	1
8	Cut models of photo voltaic cell assembly		1
9	Cut model of Lead acid battery		1
10	Lead Acid battery	12V, 40Ah, 75Ah	5
11	Lead Acid battery	12V, 100 Ah	5
12	Solar simulator for solar cell characteristic study	To study IV curve of a solar cell of minimum 2 watt under variable illumination, temperature and suitable load	1
13	Solar tracker demonstrator kit	To study manual and automatic control of 10 W solar panel in East-west and North-south & back	1
14	Solar PV e-learning software using animations for training		1
15	Lux meter	Lux meter LCD read out 0.05 to 7000 Lumens with battery.	1
16	Solar photovoltaic module	75 W mono crystalline module 75 W amorphous silicon module 250 W thin film module 5W, 10W, 40W poly crystalline module	2 each
17	Solar panels	250 Wp	5
18	Solar Charge controller with Dusk to Dawn automatic switching	12V, 10A	2
19	Solar charge controller with manual switch (Day lighting)	12V, 10A	2

20	Array junction box	for connecting 250W x 4 Nos. solar panel with DC fuse, DC MCB, and surge suppressor protection	2
21	Solar lantern	LED type	1
22	Solar lantern	CFL type	1
23	Solar lantern assembly sets		1
24	Home light system	12 V DC with FM receiver, LED bulb and mobile charger as loads	1
25	Anemometer	for wind speed measurement	1
26	PWM Controller		1
27	MPPT Charge Controller		1
28	Inverter with Battery	1 KVA with 12 V Battery Input- 12 volt DC, Output- 220 volt AC	1
29	Solar PCU Off grid	1 KW MPPT Sine wave Solar Power Conditioning Unit	1
30	Solar Grid tied inverter Demonstrator kit	300W KW	1
31	Solar Street Light	12V, 75Ah battery, 75 Wp solar panel, 12V, 10A dusk to dawn charge controller, 60 W LED lights and 9 m height pole all dismountable	1
32	Solar, wind and hybrid power plant	1 KW cumulative	1
33	solar DC pump	1 HP	1
34	1 Kw Wind Turbine	500 watts, For Domestic Purpose ; Power, 1 KW ; Blades Number, 6 ; Efficiency, 80 ; Max Speed, 400 ; Start Up Wind Speed, 2.5.	
35	Wind mill kit(DIY kit)	1kw	
36	Small hydro turbine kit(DIY kit)	1kw	
37	Biogas Portable Kit	Plant Size: 1 Cubic Meter Waste Input: 25 kg Usage/Application: Domestic	01
38	UPS 5KVA	1 phase online ups input 240v+/-10 V ac ,50 Hz 3 wire,output:5Kva,230v,Reglation +/-2%,eff 80%,charger mode should provide, battery of SMF or VRLA type backup of 4 hr at full load, functional test certificate, insulation resistance and HV test, load regulation and transient response test, efficiency , repulse ,battery capacity test , ups functional test and spare pc's - cards test reports.	2
39	Fuel Cell	Double Reversible 5W, Electrolyser Mode: 10 cm ³ /min H ₂ ; 5 cm ³ /min O ₂ ; 2.33 W, Fuel Cell Mode (O ₂): 600 mW, Fuel Cell Mode (Air): 200 mW, H x W x D: 56 x 42 x 57 mm, Wt: 63 g	5



Government of Karnataka
DEPARTMENT OF COLLEGIATE AND TECHNICAL EDUCATION

Program	Electrical & Electronics Engineering	Semester	5
Course Code	20EE541	Type of Course L:T:P	Integrated 104:52:312
Specialization	ELECTRICAL UTILITY ENGINEERING	Credits	24
CIE Marks	240	SEE Marks	160

Introduction:

The electrical power generated at the generating stations is utilized at the load end by various electrical utility equipment in the industries. Efficient utilization of electrical energy contributes to industrial growth and nation's economy. A good electrical wiring system and utility equipment are essential components for normal functioning of any type of industry. Poor design, installation, operation and maintenance of utility equipment would result in loss of electrical energy, frequent breakdowns and non-availability of service of the equipment. This course aims at developing technical skills in the students to operate, monitor, maintain and ensure healthy working condition of the most commonly used utility equipment in industries.

Pre-requisite

Before the start of this specialisation course, student shall have prerequisite knowledge gained in the first two years on the following subjects:

1st year – Engineering Mathematics, computer Aided Engineering Graphics, Fundamentals of Electrical and Electronics Engineering and Basics of Electrical power system, Communication Skills, Statistics & Analysis, Basic IT Skills, Project Management skills and Residential wiring.

2nd year- Transformers and Alternators, Transmission and Distribution, Switchgear and Protection, Analog and Digital electronics, Electrical motors, Power electronics, Fundamentals of Automation Technology and Computer Aided Electrical Drawing.

In the third year of study, student shall be applying previous years learning along with specialised field of study into projects and real-world applications.

Course Cohort Owner

A Course Cohort Owner is a faculty from the core discipline, who is fully responsible for one specialised field of study and the cohort of students who have chosen to study that specialised field of study.

Guidelines for Cohort Owner

1. Each Specialized field of study is restricted to a Cohort of 20 students which could include students from other relevant programs.
2. One faculty from the Core Discipline shall be the Cohort Owner, who for teaching and learning in allied disciplines can work with faculty from other disciplines or industry experts.
3. The course shall be delivered in boot camp mode spanning over 12 weeks of study, weekly developmental assessments and culminating in a mini capstone.
4. The industry session shall be addressed by industry subject experts (in contact mode/online / recorded video mode) in the discipline only.
5. The cohort owner shall be responsible to identify experts from the relevant field and organize industry session as per schedule.
6. Cohort owner shall plan and accompany the cohort for any industrial visits.
7. Cohort owner shall maintain and document industrial assignments, weekly assessments, practices and mini project.
8. The cohort owner shall coordinate with faculties across programs needed for their course to ensure seamless delivery as per time table
9. The cohort owner along with classroom sessions can augment or use supplemental teaching and learning opportunities including good quality online courses available on platforms like Karnataka LMS, Infosys Springboard, NPTEL, Unacademy, SWAYAM , etc.

Course outcome:

On successful completion of the course, the students will be able to:

C01	Perform routine checks on most commonly used electrical utility equipment and carry out maintenance work as per schedule.
C02	Design electrical wiring system for commercial and industrial installations, Co-ordinate with consultants and contractors during implementation stages, Identify electrical faults in electrical wiring system and initiate repair work.
C03	Design LT distribution panels as per IS and IEC standards, Generate BOM (Bill Of Materials), wire up, test and commission it. Read electrical control wiring drawings of AMF, MCC, APFC control panels, wire up and test the control panels.
C04	Identify firefighting system equipment, select and operate the appropriate class of fire extinguishers, test for the normal working condition of electrical equipment related to the firefighting system. Identify STP, ETP and rainwater harvesting equipment, operate and maintain them.
C05	Install and test UPS system, computer LAN and CCTV surveillance. Select and interface smart meters to computer network. Operate EMS (Energy Management System) and Solar power generation monitoring software. Interpret the data from EMS.

Detailed course plan

Week	C O	P O	Day	1 st session (9am to 1 pm)	L	T	P	2 ND session (1.30pm to 4.30pm)	L	T	P
1	1,2,3,4,5	2,3,4	1	<p>Introduction to types of industries-</p> <ul style="list-style-type: none"> • Broad classification. • Industry 4.0 concept. • Introduction to most commonly used utility equipment in the industries. • Meaning and Importance of utility engineering and management. • Introduction to IS , IEC, NEC - related standards and their significance. • Introduction and Significance of IE rules and ACT • Functions of -Central Electricity and State Electricity Authorities. <p>Introduction to various ISO certifications and their significance -</p> <ul style="list-style-type: none"> • ISO 9001:2015- QMS (Quality Management System) , • ISO 14001:2015- EMS- Environment Management System, • ISO 45001:2018-OHSMS- Occupational Health and Safety Management system, • ISO 8000:2014 SA- Social Accountability, • ISO 27001:2013- ISMS- Information Security Management System. 	4			<p>Draw the layout of any large scale factory showing – security room, entrance gate, exit gate, parking, transformer substation, DG power plant, LT room, UPS room, computer network server room, office, Engineering department design department, purchase department, accounts department, canteen, board room, production line, packing section, dispatch section, fire hydrant pumping station, solar power plant, rain water storage and pumping station , STP,ETP, earth pits etc. Functions of each department.</p> <p>Note: This would give an idea about overall industrial setup and understanding of role of engineering department.</p>	1		2

				<p>Concept of TQM, Functions, Features, Elements and tools of TQM-kaizen, 5S and six sigma.</p> <p>Sustainability development goals.</p> <p>Industrial Electrical Safety</p> <ul style="list-style-type: none"> • Causes and prevention of electrical accidents. • General safety practices. • Precautions to be taken during electrical repair and maintenance work. <p>Ref :2</p>						
2,3,4	1,2,3,4,5	2	<p>Electrical Maintenance Department- Objectives,</p> <ul style="list-style-type: none"> • Functions of maintenance department, • Fundamentals of maintenance. • Duties and Requirements, • Maintenance records. <p>Preparation of technical details for maintenance work, job card and log book. Machine History Card. Ref:2</p> <p>Role of maintenance department as related to satisfying the requirements from various boards/departments essential for operating an industry- Fire and Safety, Pollution control board, BWSSB, BBMP, ESCOM, Electrical Inspectorate etc.</p>	4			Identify and demonstrate the use of industrial electrician tools and meters- basic tools, megger, earth tester, lux meter, db meter, thermography meter, smart meters with communication port.	1		2
	1,5	3	<p>Design thinking</p> <p>What is design thinking?</p> <p>5 steps of Design Thinking.</p> <p>Ref.7a.b</p>	1		3	Examples of design thinking Ref.7d,e,f			3

				Why is design thinking so important? Ref.7c								
		1,5	4	Applying Design Thinking to Sustainable Energy Ref.7.i	1		3	How can 'Design Thinking' help utilities prepare for a new energy future? Ref.7.g Reinventing solar energy supply for rural Africa Ref.7.h.	1			2
			5	Developmental Assessment	-	-		Assessment Review and corrective action				3
			6	Industry Class and assessment	2		3					
Week	C O	P O	Days	1st session (9am to 1 pm)	L	T	P	2ND session (1.30pm to 4.30pm)	L	T	P	
2	1	2,3,4	1	Peer discussion on Industrial assignment		4		Sources of power supply in industries- ESCOM, DG Set And On Grid Solar PV Power Plant. Case study : Study the capacity of sources of power supply of anyone industry	2			1
	1	2,3,4	2	TRANSFORMER SUBSTATION- Types, Components of transformer substation. Selection of substation transformer capacity as per load requirements. Introduction to compact /packaged substation-construction. Name plate details of the transformer Selection of cable size of cables on primary and secondary side. Purpose of Spare incomer cable. List the accessories and fitments on a power transformer with their functions - WTI, OTI, OLI. Transformer neutral grounding and floating neutral and if effects. Preventive Maintenance of power transformer. Causes of transformer failure. Recommended maintenance schedule as per IS.	2		2	Familiarize with HT metering panel switchgears, components and their function. Note down the specifications. Transformer substation maintenance- Do various periodic checks on transformer substation. Tap changing (on/offload) and its operation. Ref :1 (Perform the experiment on disconnected old transformer if available at the campus)	1			2

				Preventive Maintenance of transformer oil and breather. Minimum breakdown values of transformer oil. Ref:2 Transformer oil filtration.							
	1	2,3,4	3	DIESEL GENERATOR SET - various devices / accessories and their function, fuel system, lubrication system, exhaust system. select suitable capacity as per load requirements, daily, weekly and monthly checks. Demonstrate operation of AVR Automatic Voltage Regulator and Electronic governing system. Function of turbocharger, AMF panel- concept, components, Block diagram and operation	2		2	Carry out maintenance work on DG set- check radiator water level, engine oil level, battery condition, AVR (automatic voltage regulator). crank and check for normal working condition. Simple trouble shooting. Visit nearby industry with diesel power plant with at least 1000 KVA capacity.			3
	1	2,3,4	4	Auto Electrical System - Wiring diagram and its working. Testing of AVR Testing of batteries.	2		2	Connect and test AVR of DG set. Check the batteries condition and Conduct load test on batteries.			3
			5	Weekly Assessment	-	-	-	Assessment Review and corrective action	-		3
			6	Industry Class and assessment	2		3				
3	1	2,3,4	1	Peer discussion on Industrial assignment		4		SOLAR HYBRID POWER PLANT - Components of solar PV ON Grid power plant and their specifications. Difference between ON grid and OFF grid Solar PV power plant. Design of solar photo-voltaic on grid power plant, monitoring energy generation. Testing and maintenance of solar PV power plant.	1		2

	1	2,3,4	2	Design a solar photo-voltaic on-grid power plant for a given roof area- No of solar panels, wiring, metering and controls. Measure kWp power generation.	1		3	Case study: Visit any industry with ON grid Solar PV power plant and prepare a report. Setup a small solar standalone power unit, connect solar panel, MPPT controller, batteries, inverter and test it. Testing and maintenance work of solar panels.			3
	1,5	2,3,4	3	INDUSTRIAL UPS SYSTEM- Types of UPS, Sizing of UPS capacity, battery type and battery backup as per load requirement. Sizing of battery connecting cables/jumps. Trouble Shooting of 3 phase UPS system.	1		3	Case study: Visit industry, note down the capacity, DC voltage and current ratings, connected load on UPS, Maintenance details and prepare a report on UPS system installed in that industry.			3
	1,5	2,3,4	4	Install and test any small capacity UPS system.			4	Install and test any small capacity UPS system.			3
			5	CIE 1- Written and practice test	-	-	-	Assessment Review and corrective action			3
			6	Industry Class + Assignment	2		3				
4	1,3	2,3,4	1	Peer discussion on Industrial assignment			4	LT DISTRIBUTION PANEL- Design a simple LT distribution panel as per load requirements consisting of metering section, indicators, digital meters-ammeter, voltmeter, trivector meter/multifunction meter, isolators, ct, busbar chamber, cable alley chamber, MCCB linked with ELR. Design factors to be considered, related IS standards. Draw SLD as per standard. Selection of power contactors, auxiliary contactors, protective devices, size of control circuit wire, power circuit wire, busbar rating, MCCB, Air Circuit Breaker. design factors to be considered Applicable standards.			3
	1,3	2,3,4	2	ACB (Air Circuit Breaker) with Motorized spring charging - Parts of ACB, control circuit and its working.			4	Prepare GA diagram and SLD using CAD. Design metering section.	1		2

				<p>EXAMPLE : Design a main LT distribution panel for the following load requirements in a factory.</p> <ul style="list-style-type: none"> • Machinshop-10 HP load, • Borewell pump-5HP x 2nos, • Office with 20 computers, • Office lighting – 1 kw, • Floor lighting for 3 floors • Street light in premises– 2 kw • Painting section - 5 KW • Lift – 5HP <p>Estimate the cost of above LT panel.</p>				<p>Selection of cables, wire sizes, switchgears and accessories. Automatic phase sequence corrector, SPP, OV, UV protection, ELR, Prepare Bill Of Materials with Specifications Note: standard sizes of lt panels with standard cuttings for meters, indicators, isolators, MCB,MCCB etc.. are available in the market. One may choose any LT distribution panel matching with their requirements, wireup and test it</p> <p>ref: Annexure</p>			
		2,3,4	3	Mount the components on the panel			4	Wire-up the power circuit of LT panel and test			3
		2,3,4	4	Wire-up the control circuit of LT panel and test			4	Wire-up the control circuit of LT panel and test			3
			5	Developmental Assessment				Assessment Review and corrective action			3
			6	Industry Class:	2		3				
5	1,3	2,3,4	1	Peer discussion on Industrial assignment	-	4	-	<p>CONTROL PANELS – Main types and their function-PCC, MCC, AMF, APFC, Design factors to be considered, Applicable IS and IEC standards. Study and read simple control panel drawings. List the control panel components. List control wiring accessories with their specifications. Preparation of ferrule numbers as per standard practice. Selection of control panel components, their ratings and wire sizes.</p>	2		1

	1,3	2,3,4	2	Design a simple AMF panel- Prepare the GA diagram, SLD and control wiring drawings as per standard practice using CAD.	1		3	Design a simple AMF panel- Prepare the GA diagram, SLD and control wiring drawings as per standard practice using CAD.			3
	1,3	2,3,4	3	Design a simple AMF panel- Design the cubicle as per standards.	1		3	Design a simple AMF panel- select the switchgears and its ratings as per load requirement.			3
	1,3	2,3,4	4	Design a simple AMF panel- Generate the BOM.	1		3	Design a simple AMF panel- Generate the BOM.			3
			5	CIE 2- Written and practice test	-	-		Assessment Review and corrective action			3
			6	Industry Class:	2		3				
Week	C O	P O	Days	1st session (9am to 1 pm)	L	T	P	2ND session (1.30pm to 4.30pm)	L	T	P
6	1,3	2,3,4	1	Peer discussion on Industrial assignment		4		Design a simple AMF panel- Mount the switchgear and accessories			3
			2	Design a simple AMF panel- Mount the switchgear and accessories			4	Design a simple AMF panel- wire up the panel as per the electrical drawings			3
	1,3	2,3,4	3	Design a simple AMF panel- Wire up the panel as per the electrical drawings.			4	Design a simple AMF panel- Test the panel.			3
	1,3	2,3,4	4	Visit nearby industry and prepare a report on PCC, MCC, APFC panel, Fire hydrant pump control panel, STP and ETP control panel.			4	Visit nearby industry and prepare a report on PCC, MCC, APFC panel, Fire hydrant pump control panel, STP and ETP control panel.			3
			5	Developmental Assessment	-	-	-	Assessment Review and corrective action			3
			6	Industry Class:	2		3				
7	1,2	2,3,4	1	Peer discussion on Industrial assignment		4		INDUSTRIAL WIRING- Identify and list the industrial range electrician tools, cabling/wiring accessories. Note down the specifications.	1		2
	1,2	2,3,4	2	INDUSTRIAL WIRING-	1		3	INDUSTRIAL WIRING-	1		2

				Busbar trunking and rising mains, Design of LT distribution system for a given factory layout or an apartment per applicable standards.				Lighting – Design lux levels as per standards, Design energy efficient illumination for the given factory layout or an apartment, Design lighting circuit and its distribution board. Methods to reduce energy consumption towards lighting.			
	1,2	2,3,4	3	Design the conduit layout for lighting circuit using cad as per standards.	1		3	Design the conduit layout for lighting circuit using CAD as per standards.			3
	1,2	2,3,4	4	Prepare the BOM for lighting circuit.	1		3	Estimate the cost for industrial wiring for lighting circuit.			3
			5	CIE 3 Written and practice test	-	-	-	Assessment Review and corrective action			3
			6	Industry Class:	2		3				
8	1,2	2,3,4	1	Peer discussion on Industrial assignment	-	4	-	Power circuit- Design power circuit for power outlets as per requirement for the given factory layout. Design suitable distribution panels, select suitable size of cables, protective devices and switch gears. Applicable standards			3
	1,2	2,3,4	2	Design the conduit layout/cable tray layout for power circuit using CAD as per standards.	1		3	Prepare the BOM for power circuit.	1		2
	1,2	2,3,4	3	INDUSTRIAL PUMPS- Types and their application Select borewell pump for a given discharge and head. Identify types of valves and their applications.	1		3	Connect a 3 phase, 415 v, 3 ph bore well or open-well submersible pump with suitable starter. Interconnect 3ph starter and 3 phase automatic water level control. Manually simulate and test for normal operation Dis-assemble any one type of motor pump set, identify the parts, service, re-assemble and test			3

								Note: The above experiment setup shall be done indoor and tested.			
	1,2	2,3,4	4	Connect a 3 phase, 415 v ,3 ph. bore well or open well submersible pump with suitable starter. Interconnect 3ph starter and 3 phase automatic water level control. manually simulate and test for normal operation Dis-assemble any one type of motor pump set, identify the parts, service, re-assemble and test	1		3	EARTHING SYSTEM in industries and its maintenance. Earth mats, Standard values. Testing and maintenance of earth pit, methods of reducing earth resistance, equipment earth, neutral earth, power circuit earthing, lightening arrestor earthing, Visit nearby industry and prepare a report on LT distribution system, lighting system, power circuit and earthing system.	1		2
		5	Developmental Assessment		-	-	-	Assessment Review and corrective action			3
		6	Industry Class:		2		3				
9	1,2	2,3,4	1	Peer discussion on Industrial assignment		4		COMMUNICATION AND COMPUTER NETWORK- Computer network components / devices/accessories, list of materials and their specification.	1		2
	1,2	2,3,4	2	COMMUNICATION AND COMPUTER NETWORK- Meaning of data communication and computer network, OSI layers, types of network and their applications, classification of network architectures, networking devices/components-workstation, Hub, Bridge, Repeater, switch, router, server...server types , networking terminologies...subnet, internet, intranet, ethernet, bandwidth, IP address, TCP/IP, LAN, WAN,CAN,	2		2	Wired networking cables-category 3/5/6/6A/7 and their standards and speeds. Fibre optical cables- General construction, working and application. Crimping exercise- LAN network cable and RJ45 connector.	1		2

				WLAN,MAN,SAN, firewall, functions of router, network topologies and their application, Communication protocols and their applications- RS232, RS485, modbus, profibus and BACnet. Prepare the list of materials with specifications to set up a LAN for an office or a computer lab with 20 computers							
	1,2	2,3,4	3	Design and setup LAN for an office or computer lab with 20 computers. Select suitable network switch, cable. Connector and power supply. Connect, configure and test the LAN	1		3	Design and setup LAN for an office or computer lab with 20 computers. Select suitable network switch, cable. Connector and power supply. Connect, configure and test the LAN			3
	1,2	2,3,4	4	CCTV SURVELANCE- Types and applications, components / devices required and their specifications. Design CCTV surveillance system for a given layout of an industry, Select - DVR, NVR, type of camera, coaxial cable and display unit. Design conduit layout and cabling system. List the materials and estimate their cost	2		2	Connect DVR, Power Supply, Camera, Configure and Test CCTV by rigging up on the work table in the laboratory.	1		2
			5	CIE 4 Written and practice test	-	-	-	Assessment Review and corrective action			3
			6	Industry Class:	2		3				
10	1,2	2,3,4	1	Peer discussion on Industrial assignment		4		LIFTS- Types, construction and working, major components, type and specification of motor, essential spares, controllers operation and	3		

								maintenance. selection of lifts capacity as per requirement, and erection procedures.			
	1,2	2,3,4	2	ESCALATORS- construction and working, major components, type and specification of motor, operation and maintenance. INDUSTRIAL OVERHEAD CRANES- construction and working, major components, type and specification of motor. Operation and maintenance. Controller, type of motor and specifications.	2	2	General maintenance and servicing of lifts, escalators and cranes. simple trouble shooting Visit nearby industry and document the details found. Ref: 3	1		2	
	1,2	2,3,4	3	HVAC EQUIPMENT- Block diagram, Main components, construction, operation and maintenance of centralized air conditioning plant , chillers, AHU, FCU, blowers, compressors , condensers, cooling tower etc.. note down the specification of all the above components. Methods to reduce energy consumption towards HVAC.	2	2	Visit nearby industry and document the details found.			3	
	1,2	2,3,4	4	Visit nearby industry and document the details found.		4	Visit nearby industry and document the details found.			3	
			5	Developmental Assessment			Assessment Review and corrective action			3	
			6	Industry Class:	2	3					
11	1,2,4	2,3,4	1	Peer discussion on Industrial assignment	-	4	- FIRE FIGHTING SYSTEM- Causes of fire, type and class of fire extinguishers their application. installation of smoke detectors, heat sensors, fire annunciation and alarm panel,	3			

							PA system, fire hydrant system-sprinklers, water curtain, water jet/spray,			
1,2,4	2,3,4	2	Selection of main pump, jockey pump. Starter control panel Select DG set capacity for fire hydrant pump as per requirements Operation and Maintenance. Draw the layout of fire hydrant system pump house for a given shopping complex or a factory layout.	2		2	Read the electrical drawings of the power circuit and control circuit of fire hydrant pumps. Draw the wiring layout of smoke detectors. Draw the wiring layout of PA system. Procedure for testing of fire hydrant system. Connect and test -smoke detector, heat sensor, fire console, PA system etc..	1		2
1,2,4	2,3,4	3	RAIN WATER HARVESTING SYSTEM- Components of rain water harvesting system. Pumping station- selection of pump. method of measuring rainfall , available rain water collection and storage. Design simple rain water harvesting system depending on the land area of the industry. List the materials required with their specification.	2		2	Visit nearby industry and prepare a report on the firefighting system and rain water harvesting system. Prepare a detailed report on volume of water collected during a year. Co-relate water consumption from bore well with and without rain water harvesting			3
1,2,4	2,3,4	4	STP AND ETP PLANT- Block diagram, construction and working. Components of STP and their functions. Components of ETP and their functions. Operation and Maintenance of STP and ETP	4			Visit nearby industry and study the operation and maintenance of STP and ETP. Co-relate amount of fresh water saved due to recycling the water. Prepare a report.			3
		5	CIE 5 Written and practice test	-	-		Assessment Review and corrective action			3
		6	Industry Class:	2		3				

12	1,5	2,3,4	1	Peer discussion on Industrial assignment	-	4	-	Energy Management System (EMS) - Energy flow in industries -General block diagram, Components and their functions. Building Automation System (BAS)/Building Management System (BMS) -General Block diagram ,Components and their functions. Merits and Demerits of BAS/BMS IOT - Components and their functions. Applications of IOT in industries.	3		
	1,5	2,3,4	2	Install any open source software, interface hard ware with software, read current, voltage, power, energy , power factor and display the energy generated by various sources in form of graph and pie chart	2		2	Install any open source software, interface hard ware with software, read current, voltage, power, energy , power factor and display the energy generated by various sources in form of graph and pie chart			3
	1,5	2,3,4	3	ENERGY MANAGEMENT – Meaning, need, Approaches and General principles. ENERGY AUDIT -Meaning, Types, Pre-requisites, methodology/procedure, scope of energy audit. Data collection and Data Analysis. General formats used for energy audit. Energy Management opportunities in industrial lighting and heating.	4			Note down the type, ratings of domestic appliance- electric iron, geyser, fan, food mixer, washing machine. Identify the type of motors used in domestic appliances.			3
	1,5		4	Conduct energy audit of home / college campus/any one industry Collect the details in a standard format. Compare energy consumption with energy bill. Suggest suitable remedies to reduce energy consumption and energy bill.	1		3	Introduction to AMC. (Annual Maintenance Contract) Need for AMC, Scope of AMC for major equipment like AMC for UPS system AMC for DG set AMC for HVAC AMC for Elevators			3

								Case study: visit near by industry , note down various AMC details and submit a report.			
			5	Developmental Assessment				Assessment Review and corrective action			3
			6	Industry Class:	2		3				
Week	C O	P O	Days	1st session (9am to 1 pm)	L	T	P	2ND session (1.30pm to 4.30pm)	L	T	P
13	1,2,3,4,5	2,3,4		Internship a) Secondary research on various industries and their operations to identify at least 3 companies along with the areas of work interest and develop an internship plan that clearly highlights expectations from the industry during the internship. b) Design and develop a cover letter for an internship request to all 3 identified companies and the resume to be submitted to potential companies. c) Prepare for an internship interview to highlight your interests, areas of study, career aspirations and personnel competence – including the areas of learning you expect to learn during internship			4	Project a) Identification of the problem statement (from at least 3 known problems) the students would like to work as part of the project – either as provided by faculty or as identified by the student. Document the impact the project will have from a technical, social and business perspective. b) Design and develop the project solution or methodology to be used to solve at least one of the problems identified. Prepare a project plan that will include a schedule, WBS, Budget and known risks along with strategies to mitigate them to ensure the project achieves the desired outcome.			3

References:

Sl No	Description	Reference / Link
1	Building Electricals design	Electricity in buildings, GOOD PRACTICE GUIDE, International Copper Association India. – McGrawHill
2	Maintenance of electrical equipment	Installation Maintenance and Repair of Electrical Machines and Equipments by Madhvi Gupta- KATSON BOOKS.
3	Electrical system design	Electrical system design- T. Giridharan – wiley publication

4	Electrical Installation for Modern Buildings	Electrical Installation for Modern Buildings- M.P. krishna Pillai- Standard Publishers and Distributors https://s3.ap-south-1.amazonaws.com/aipnpc.org/downloads/T_5052_ENERGY_EFFICIENCY_IN_ELECTRICAL_UTILITIES_BOOK_03.pdf
5	Energy Efficiency in Electrical Utilities	https://mppolytechnic.ac.in/mp-staff/notes_upload_photo/CS595EnergyEfficiencyinElectricalUtilities-5391.pdf
6	Electrical Power Distribution	Hand book of Electrical Power Distribution by Gorti Ramamurthy , Universities Press
7	Operation and maintenance of Transformers	Operation and maintenance of Transformers – hand book by H N S Gowda, published by H N S Gowda , No. 98, 7 th A main, 3 rd Block, 4 th stage Basaveshwaranagar, Bangalore 560079. Phone: 080-23203070
8	Electrician tools	https://www.youtube.com/watch?v=PAPPwrCPIqg
9	Design thinking	a. https://careerfoundry.com/en/blog/ux-design/design-thinking-examples/ b. https://online.hbs.edu/blog/post/design-thinking-examples c. https://www.healing-power-of-art.org/positive-art-news-creativity-turns-scary-mri-scanner-for-kids-into-an-adventure/ Examples of design thinking d. https://careerfoundry.com/en/blog/ux-design/design-thinking-examples/ e. https://online.hbs.edu/blog/post/design-thinking-examples f. https://www.healing-power-of-art.org/positive-art-news-creativity-turns-scary-mri-scanner-for-kids-into-an-adventure/ g. https://www.linkedin.com/pulse/how-can-design-thinking-help-utilities-prepare-new-energy-singh h. https://thisisdesignthinking.net/2016/05/reinventing-solar-energy-supply-for-rural-africa/ i. http://innodigest.com/design-thinking-to-sustainable-energy/
10	Compact substation	https://www.youtube.com/watch?v=3Yo_g_WfQSs
11	Transformer substation SLD	https://www.youtube.com/watch?v=wlgcF4ynTB8
12	AVR wiring of DG set	https://www.youtube.com/watch?v=82BsoaVKKBw https://www.youtube.com/watch?v=3FCBovUH0-M
13	DG set governor	https://www.youtube.com/watch?v=TGpAH1W-0ss
14	DG set maintenance	https://www.youtube.com/watch?v=JCv_uR4FqHM https://www.youtube.com/watch?v=gZzBhXQjjY8

15	DG starting problem	https://www.youtube.com/watch?v=XwvPq_OWFjA
16	Automatic changer over switch for DG set	https://www.youtube.com/watch?v=PnlVNb2I524
17	Automatic change over switch	https://www.youtube.com/watch?v=-QjPlnWErTE https://www.youtube.com/watch?v=-QjPlnWErTE
18	Solar inverter connection diagram	https://www.youtube.com/watch?v=x-05gKrdg3U
19	Solar power calculation	https://www.youtube.com/watch?v=4WAgQ_19B5k
20	Solar grid tie system	https://www.youtube.com/watch?v=WuXcuQSToTE
21	Types of control panel	https://www.youtube.com/watch?v=tDhyy72peI0
22	How to Read Electrical Diagrams	https://www.youtube.com/watch?v=GHhcyH99inE
23	How to Read Electrical Schematics	https://www.youtube.com/watch?v=Et-gHKTdziU
24	AMF panel	https://www.youtube.com/watch?v=X2fL8AV2fv4 https://www.youtube.com/watch?v=tidxKmtUBBE https://www.youtube.com/watch?v=4KvRnkuswD0 https://www.youtube.com/watch?v=0s5XBMfawlk
25	Contactor selection and sizing	https://www.youtube.com/watch?v=loIsoKQWjSY
26	Cable size calculation	https://www.youtube.com/watch?v=z7kArhBowxg
27	Different Types of Electrical Wires and Cables	https://www.electricaltechnology.org/2020/04/types-wires-cables.html
28	HVAC system	https://www.youtube.com/watch?v=iX4-06A7bJ8 https://www.youtube.com/watch?v=ScVBPAitibQ
29	Building Management system	https://www.youtube.com/watch?v=eoUha0APBIU https://www.youtube.com/watch?v=rgk7UdEWMpQ

30	Fire fighting hydraulics calculation	https://www.youtube.com/watch?v=QcM9dWpF1-c
31	Fire sprinklers	https://www.youtube.com/watch?v=DjvcDCo-MA https://www.youtube.com/watch?v=Gmi1dTP4DMo https://www.youtube.com/watch?v=yCllHMvQ_0 https://www.youtube.com/watch?v=osyyLey5ipU https://www.youtube.com/watch?v=1wB8WkbaXpc
32	Fire alarm system	https://www.youtube.com/watch?v=cVjyDgFrb2g
33	Fire alarm panel	https://www.youtube.com/watch?v=ui3t0PnCPRo https://www.youtube.com/watch?v=rZ_2PjskrAM https://www.youtube.com/watch?v=xmNZUPIfebE
34	Smoke detector connection	https://www.youtube.com/watch?v=ORjybbBXxRQ https://www.youtube.com/watch?v=VpKydvGn_js
35	Fire detection panel	https://www.youtube.com/watch?v=3NhSNgT3LNA https://www.youtube.com/watch?v=s17FhnnwsA8
36	Classification of fire extinguishers and classes of fire	https://www.youtube.com/watch?v=yzGe_8bvSE0
37	Fire Emergency Procedures	https://www.youtube.com/watch?v=7gHEtGY4chE
38	Fire prevention at work place	https://www.youtube.com/watch?v=ReL-DM9xhpI
39	How to use fire extinguishers	https://www.youtube.com/watch?v=PQV71INDaqY
40	Computer networking	https://www.youtube.com/hashtag/networkingbasics https://www.youtube.com/watch?v=1z0ULvg_pW8
41	Network cables	https://www.youtube.com/watch?v=_NX99ad2FUA
42	IP addressing	https://www.youtube.com/watch?v=ThdO9beHhpA
43	CCTV basics	https://www.youtube.com/watch?v=e3JZWDyG6Yk
44	CCTV wiring	https://www.youtube.com/watch?v=urrJ0Pnlzc0 https://www.youtube.com/watch?v=AQ1EPI_4O2w
45	RJ45 crimping	https://www.youtube.com/watch?v=SrdFw6Kunxo
46	Sewage treatment plant	https://www.youtube.com/watch?v=b0G8R2Yfw5k
47	Cable tray sizing	https://www.youtube.com/watch?v=9PHN2zTNZT0
48	Electrical design for high rise buildings	https://www.youtube.com/watch?v=z6_7jpO8zPE

CIE and SEE Assessment Methodologies

CIE Assessment	Assessment Mode	Duration In hours	Max Marks
Week 3	CIE 1- Written and practice test	4	30
Week 5	CIE 2- Written and practice test	4	30
Week 7	CIE 3- Written and practice test	4	30
Week 9	CIE 4- Written and practice test	4	30
Week 11	CIE 5- Written and practice test	4	30
	On line Course work (Minimum 10 hours online course with certification from (SWAYAM/NPTEL/Infosys Springboard)		40
	Profile building for Internship / Submission of Synopsys for project work		20
Portfolio evaluation (Based on industrial assignments and weekly developmental assessment) *			30
TOTAL CIE MARKS (A)			240
SEE 1 - Theory exam (QP from BTE) Conducted for 100 marks 3 hrs duration reduced to 60 marks		3	60
SEE 2 - Practical		3	100
TOTAL SEE MARKS (B)			160
TOTAL MARKS (A+B)			400

* The industrial assignment shall be based on peer-to-peer assessment for a total of 10 marks (on a scale of 1 to 10) and in the event of a group assignment the marks awarded will be the same for the entire group, the developmental assessment will be for a total of 20 marks and based on MCQ/case study/demonstration and such other assignment methods

Assessment framework for CIE (1 to 5)

Note : Theory to be conducted for 1 hour and practice for 3 hours, total duration of exam - 4 hours

Programme	Electrical & Electronics Engineering	Semester	V		
Course	ELECTRICAL UTILITY ENGINEERING	Max Marks	30		
Course Code	20EE54I	Duration	4 hours		
Name of the course coordinator					
Note: Answer one full question from each section.					
Qn.No	Question	CL L3/L4	CO	PO	Marks
Section-1 (Theory) - 10 marks					
1)	Design GA diagram of an LT panel of factory with the following loads. <ul style="list-style-type: none"> • Machinshop-3 phase, 10 HP load, • Borewell pump- 3 phase 5HP x 2nos, • Office with 20 computers, • Office lighting - 1 kw, • Floor lighting for 3 floors • Street light in premises- 2 kw • Painting section - 3phase 5 KW • Lift -3 phase 5HP 	L3	1	3	10
2)	Select a suitable transformer for a factory with load of 150 HP and write its specifications	L4	1	1,2	10
Section-2 (Practical) - 20 marks					
3)	Conduct routine test on DG set and check for the normal working conditions of the DG set.	L3	1	4	20
4)	Commission and test the given UPS and batteries.	L3	1	4	20

Note : Theory questions shall be aligned to practical questions

Assessment framework for SEE 1 (Theory)

Programme :	Electrical & Electronics Engineering	Max Marks :	100
Semester :	V	Duration :	3 Hrs
Course :	ELECTRICAL UTILITY ENGINEERING		
Course Code :	20EE54I		

Instruction to the Candidate: Answer one full question from each section.

Q.No	Question	CL	CO	Marks
Section-1				
1.a)	Select a suitable DG set for an apartment with the following load requirements. <ul style="list-style-type: none"> • Borewell pump – 3 HP x 2 Nos. • Sump pump – 2 HP • Lift – 5HP • Common Area lighting – 1 KW • 12 houses each with 5 KVA load 	L3	1	10
b)	List the causes for voltage fluctuation in a DG set.	L4		5
c)	It was observed that all the 3 phase equipment in a factory like lifts , water pumps , lathes etc suddenly started malfunctioning after a maintenance job undertaken by the power supply company on HT line. What could be the reason for malfunction of the equipment which were working properly before maintenance work?	L3		5
2.a)	Select a suitable transformer for a factory with 150 HP load and writes its specifications.	L3	2	10
b)	While checking a transformer, it is found that the breakdown voltage of its oil is 20 KV. What are the corrective actions to be taken.	L4		5
c)	One particular phase of a 3 phase cable in a factory keeps burning often. On measuring the load current , it was found to be within the normal. range of the cable. On scanning the temperature using a thermography meter, the temperature was found to be 75 degree centigrade. What could be the reason for over heating up of the cable?	L3		5
Section-2				
3.a)	Select a suitable starter for a 5 HP submersible borewell pump set and write its specifications	L3	2	10

b)	On measuring the line current using of a 3 phase 10 HP induction motor it is observed that the current drawn is 20 A. What should the normal rated current of the motor and what should be the OLR setting on the starter.	L4		5
c)	It is observed that a raw water pump motor switches ON but the starter trips after few seconds. While the motor windings , starter and wirings are found to be in good condition, On checking the 3 phase power supply using a neon tester, the neon tester glows on both incoming and outgoing sides of fuse units at LT panel end as well as Motor Starter end. What could be the reason for motor starter tripping	L4		5
4)	Design illumination for a factory shed measuring 60 L x 15 W x 9 H. Select suitable type of light fitting , draw the arrangement of lighting points and conduit layout for wiring	L4		20
Section- 3				
5.a)	Design and draw the GA diagram of an LT panel for a factory with the following loads. <ul style="list-style-type: none"> • Machinshop-10 HP load, • Borewell pump-5HP x 2nos, • Office with 20 computers, • Office lighting – 1 kw, • Floor lighting for 3 floors • Street light in premises– 2 kw • Painting section - 5 KW • Lift – 5 HP 		3	15
b)	Draw the SLD for the above LT panel.	L3		5
6.a)	Design and draw the control circuit of an AMF panel, label the parts and mark the ferrule numbers for the wires.	L3		15
b)	Write the specification of ELR suitable for commercial building with 100 KVA load			5
Section-4				
7.a)	Draw neat block diagram of STP and explain the maintenance carried out on STP.	L3	4	10
b)	With a neat layout diagram explain fire hydrant system and its components.	L3		10
8. a)	Explain various routine tests on firefighting system equipment.	L4		10
b)	List the classes of fire and the type of fire extinguisher to be used on them.	L4		10
Section-5				

9.a)	Design an LAN system for an office with 20 computers. List the components / devices/cables/connectors etc.. required with their specifications.	L3	5	10
b)	Design an CCTV surveillance system for a factory premises to cover 10 zones including 2 outdoor/ open area zones. List the components/ devices/cables /connectors etc.. required with their specifications.			10
10.a)	Design UPS system for an office with 25 KVA load. Select the UPS capacity, type of UPS and batteries for 3 hours backup.	L3		15
b)	It was observed that the UPS is not supplying the load during power failures. List the possible causes and suggest suitable remedies.	L4		5

Scheme of Evaluation for SEE 2

Sl. No	Description	Marks
1	Demonstrate routine checks on DG set/ trouble shoot DG set electrical problems/transformer substation/Earthing system	10
2	Test and Identify faults in electrical wiring system (conduct OC, SC and Insulation resistance test on the electrical installations)	10
3	Reading of control wiring drawing and identifying control panel components/Demonstrate ferrule numbering as per standards	10
4	Tracing and testing control wiring of LT control panel/AMF panel/APFC panel.	10
5	Install and test – 3 phase Submersible pump starter with water level controller /UPS system/ CCTV/LAN/ fire alarm/annunciation panel a. Circuit diagram and Procedure= 15 b. Connection =25 c. Testing =10 Note : the above experiment may be setup on table and demonstrated	50
6	Select appropriate fire extinguisher and operate / Demonstrate operation of firefighting control panel/ PA system/Alarm/Annunciation panel.	10
Total		100

Equipment/Software list with Specification for a batch of 20 students

Sl. No.	Description of the equipment/ Hardware/ Software	Specification	Total Quantity Required (A)
1	Digital megger	1000 V	2
2	Digital earth tester	1000 V	2
3	Hand driven megger	2500 V	2
4	Hand driven earth tester	1000 V	2
5	Lux meter	Any Basic model	2
6	Sound level meter	Any Basic model	2
7	Thermography meter	Any Basic model	1
8	Hydraulic crimping tool	16 to 400 sqmm	2
9	LT Distribution panel with 200 A MCCB, ELCB, 200 A Isolator -4 nos,32 A TPMCB 2 Nos, 16 A DP MCB 4 Nos. Digital meters- Ammeter, Voltmeter, Multifunction meter	set	1
10	AMF panel with ACCL and meters	Basic features	1
11	APFC Panel with Capacitor bank	3 ph 6 KVAR	1
12	Fire hydrant pump control panel	5 HP	1
13	Fire alarm control panel	8 zones	1
14	Fire PA system	8 zones	1
15	CCTV demonstration set	4 channel DVR with power supply cameras etc..	1
16	Computer Networking demo set	set	1
17	Network cable tester	Any Basic model	2
18	Miscellaneous items.. tool set, basic meters ...		2
19	Basic Industrial Tools, Meters-Thermography meter, Lux meter, DB meter, Megger, Earth tester, smart meters and PPE kit		
20	Solar PV standalone demonstration setup.	3kW	2
21	AVR and electronic governor of DG set		2

22	Any Small capacity UPS with batteries.	Upto 1 KVA capacity	2
23	Firefighting- smoke detector, Heat sensor, simple -PA system, Alarm console, fire hydrant pump control panel.		2